

T262XS

Published:07/26/2018

TABLE OF CONTENTS

CYLINDER, PISTON, CRANKSHAFT.....	1
CRANKCASE	3
MAGNETO.....	5
CLUTCH.....	7
AIR CLEANER, CARBURETOR.....	9
CARBURETOR.....	11
FUEL TANK.....	13
MUFFLER	15
RECOIL STARTER, PULLY	17
GEAR CASE, SHIELD.....	19
MAIN PIPE, HANDLE.....	21
THROTTLE	23
ACCESSORIES	25
NYLON LINE CUTTER.....	27

CYLINDER, PISTON, CRANKSHAFT

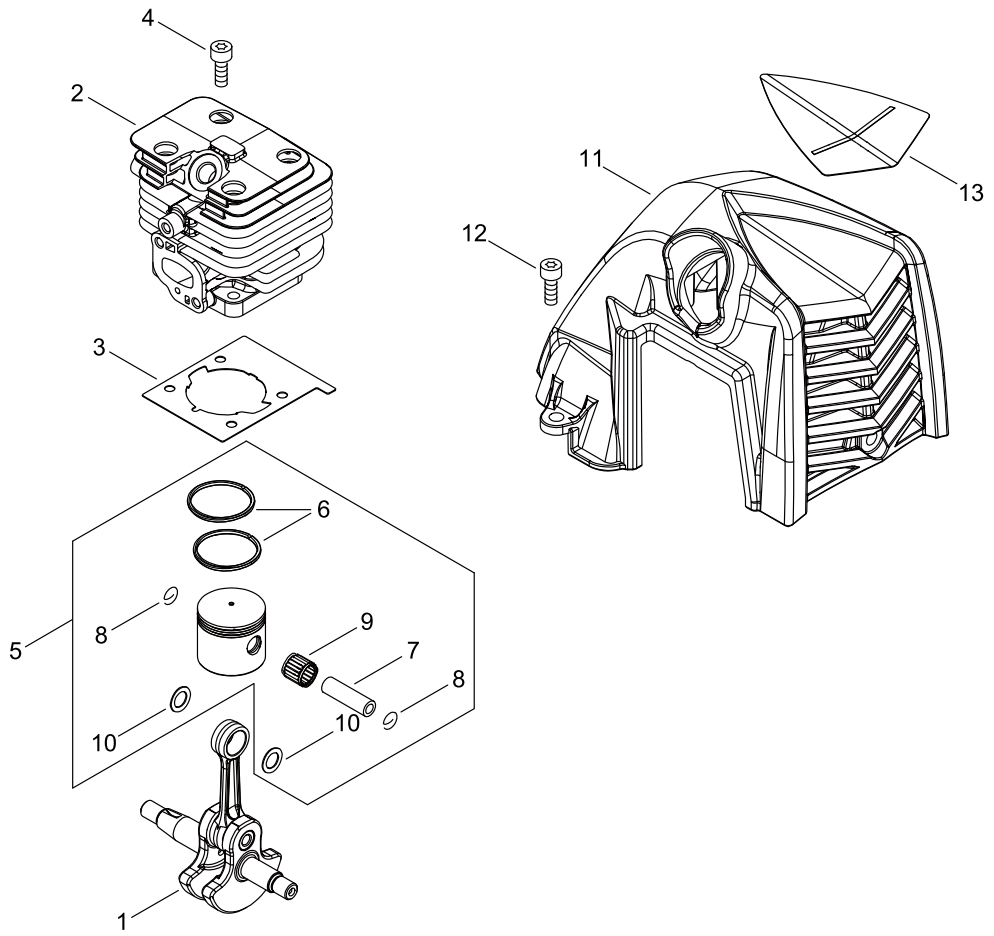

CYLINDER, PISTON, CRANKSHAFT

KEY NO	LV(+)	Part No	Description	Qty	Standard	Comment
1		A011-001460	CRANKSHAFT,ASY	1		
2		A130-002330	CYLINDER	1		
3		V100-000840	GASKET,CYL	1		
4		V805-000210	BOLT, TORX 5	4	TB-5*20 12.9	
5		P021-050840	PISTON KIT	1		
6	+	A101-000010	RING,PISTON	2		
7	+	100013-35430	PIN, PISTON	1	6*9*27.8	
8	+	100015-03931	CIRCLIP, PISTON PIN	2		
9	+	V554-000020	BEARING,NEEDLE 9	1	KTV-91212EG14-B2	
10	+	100014-53630	SPACER, PISTON PIN	2		
11		A160-003290	COVER,CYLINDER	1		
12		V805-000140	BOLT, TORX 5	2	TB-5*12 10.9	
13		X562-000350	LABEL,SHINDAIWA	1		

CRANKCASE

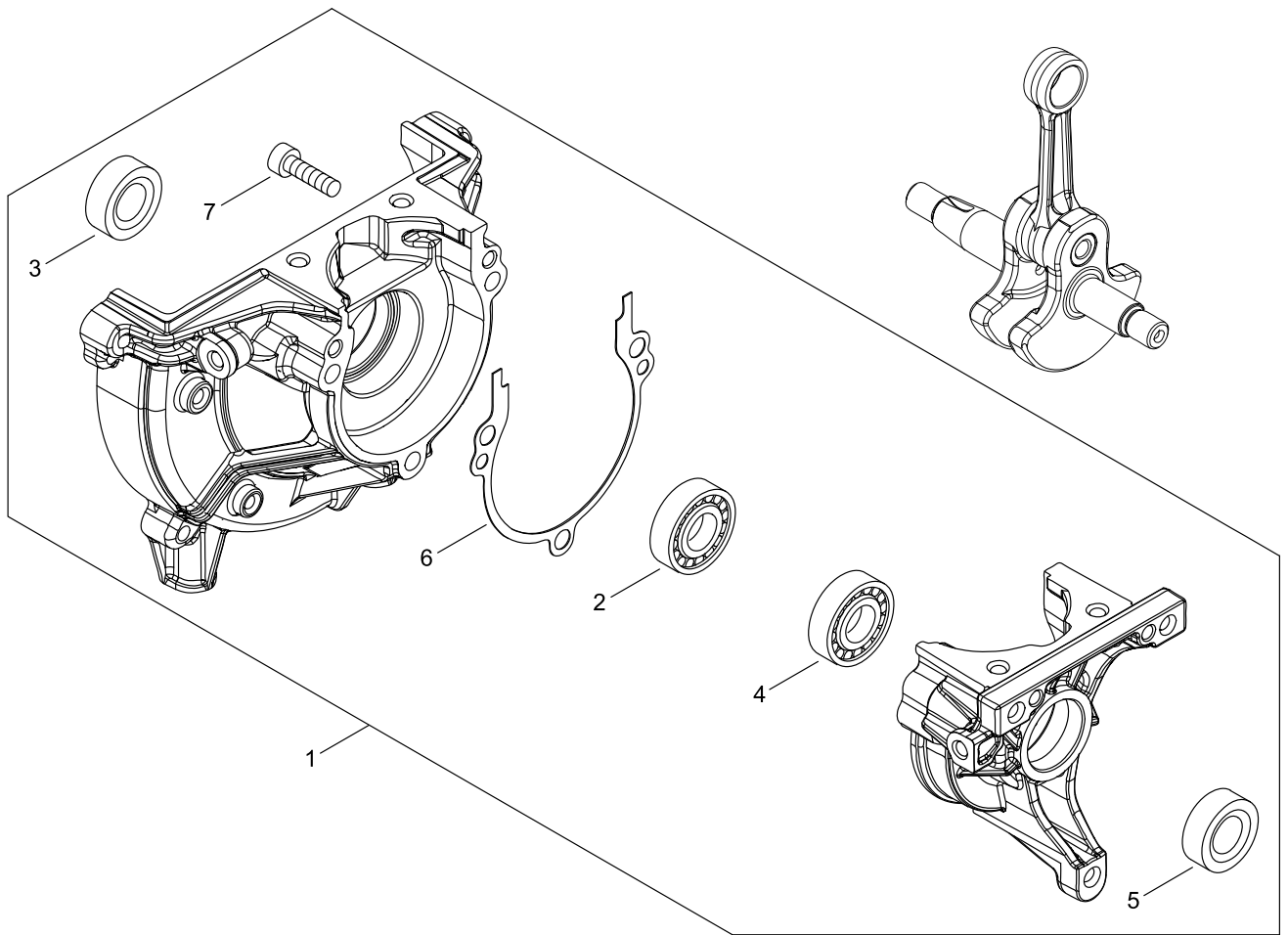

CRANKCASE

KEY NO	LV(+)	Part No	Description	Qty	Standard	Comment
1		P021-050850	CRANKCASE KIT	1		
2	+	900800-36001	BEARING, BALL 6001	1	6001/C3	
3	+	100212-42031	OILSEAL	1	ISCD 12*22*4.5	
4	+	900810-36000	BEARING, BALL	1	6000	
5	+	V503-000040	SEAL,OIL 10	1	ISCD 10*20*5F	
6	+	V102-000300	GASKET,CRANKCASE	1		
7	+	V805-000220	BOLT, TORX 5	3	TB-5*25 12.9	

MAGNETO

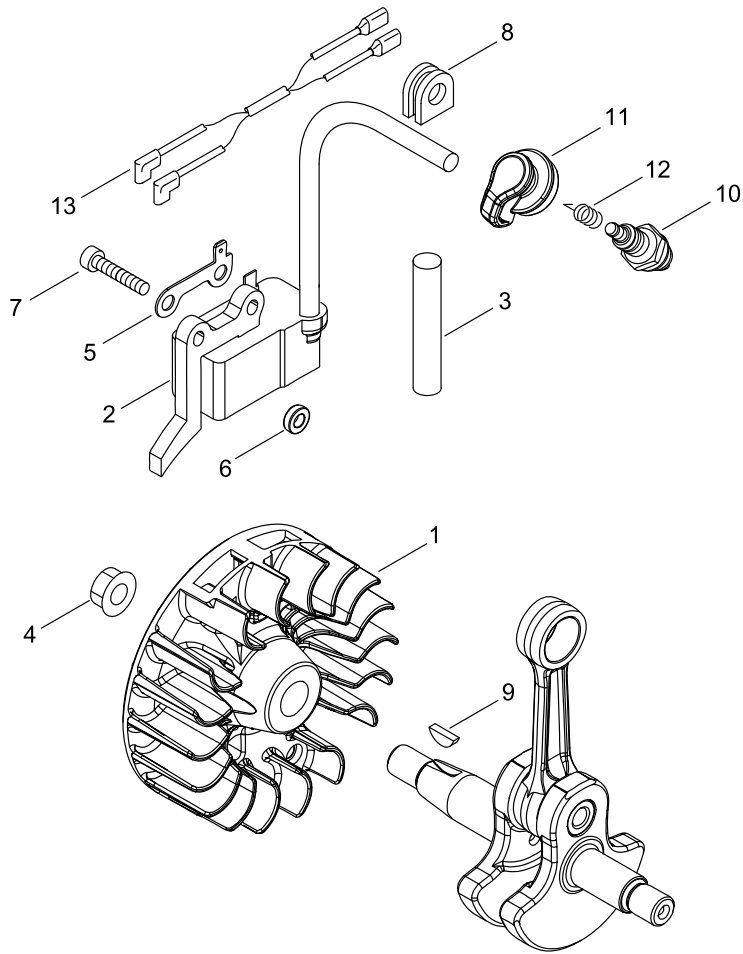

MAGNETO

KEY NO	LV(+)	Part No	Description	Qty	Standard	Comment
1		A409-001320	ROTOR, MAGNETO	1		
2		A411-001710	COIL, IGNITION	1		
3		V475-007540	TUBE	1		
4		900515-00008	NUT, FLANGE 8	1	8	
5		C152-001030	CONNECTOR	1		
6		V323-000070	WASHER,CIRCULAR 5	2	5.2*10*3	
7		V805-000210	BOLT, TORX 5	2	TB-5*20 12.9	
8		156110-04920	BUSHING	1		
9		100142-12330	KEY, WOODRUFF	1		
10		A425-000060	SPARKPLUG	1	CMR7H	
11		A427-000220	CAP,SPARK PLUG	1		
12		A426-000010	TERMINAL,SPARKPLUG	1		
13		V485-002880	LEAD	1		

CLUTCH

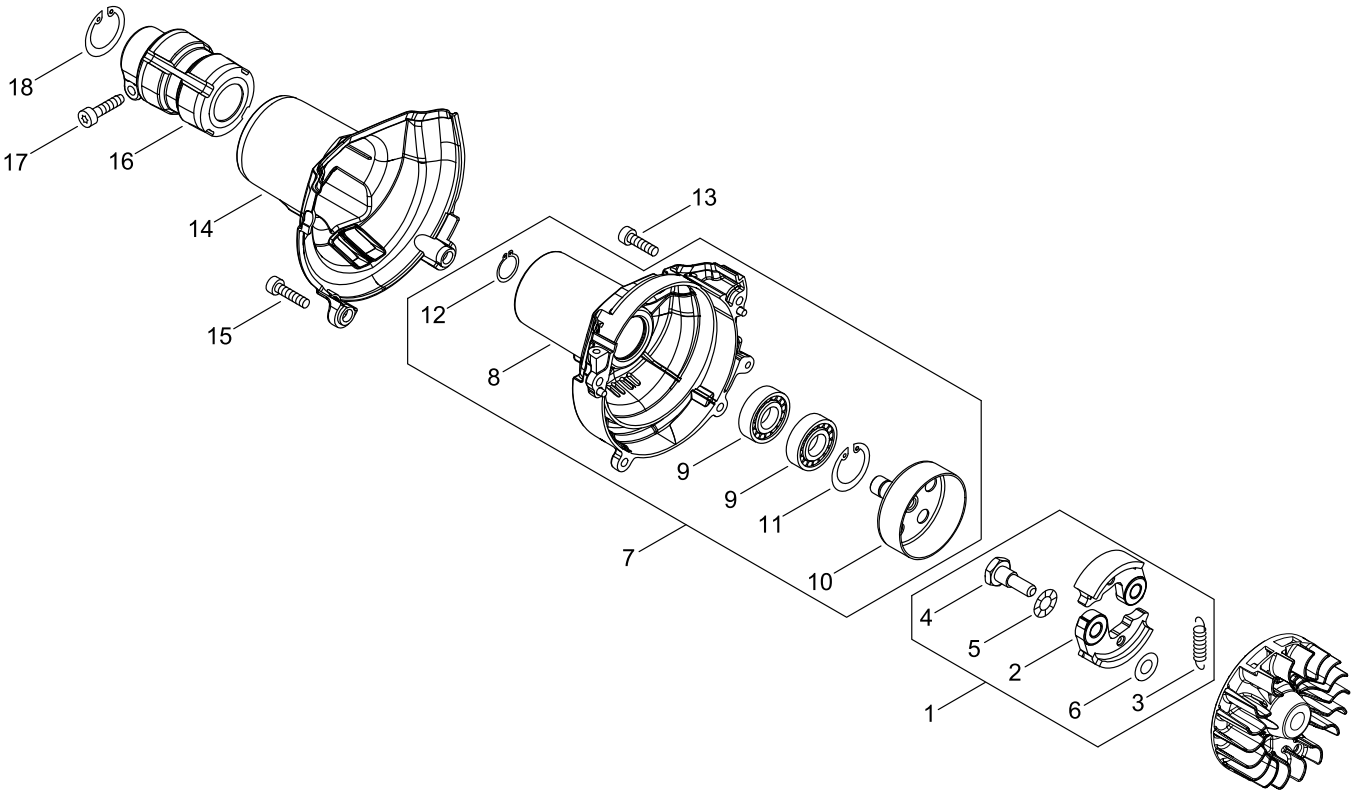

CLUTCH

KEY NO	LV(+)	Part No	Description	Qty	Standard	Comment
1		P021-050860	CLUTCH ASY	1		
2	+	A553-000190	ARM, CLUTCH	2		
3	+	V451-001390	SPRING,TENSION	1	172N/34MM	
4	+	175046-56030	SHAFT, CLUTCH	2		
5	+	175049-56030	WASHER	2	8.5*16*0.5	
6	+	175048-05530	WASHER (I)	2	6.2*19*1.0	
7		P021-051000	FAN COVER ASY	1		
8	+	A172-003140	COVER,FAN	1		
9	+	900807-06001	BEARING, BALL 6001	2	6001V(LB)	
10	+	A556-001750	DRUM, CLUTCH	1		
11	+	900702-00028	CIRCLIP 28	1	CR-28	
12	+	900701-00012	CIRCLIP 12	1	CS-12	
13		V805-000150	BOLT, TORX 5	2	TB-5*16 10.9	
14		A413-000090	BOOT	1		
15		V805-000160	BOLT, TORX 5	2	TB-5*20 10.9	
16		A575-000690	FIXTURE, MAIN PIPE	1		
17		V805-000170	BOLT, TORX 5	1	TB-5*25 10.9	
18		900702-00042	CIRCLIP 42	1	CR-42	

AIR CLEANER, CARBURETOR

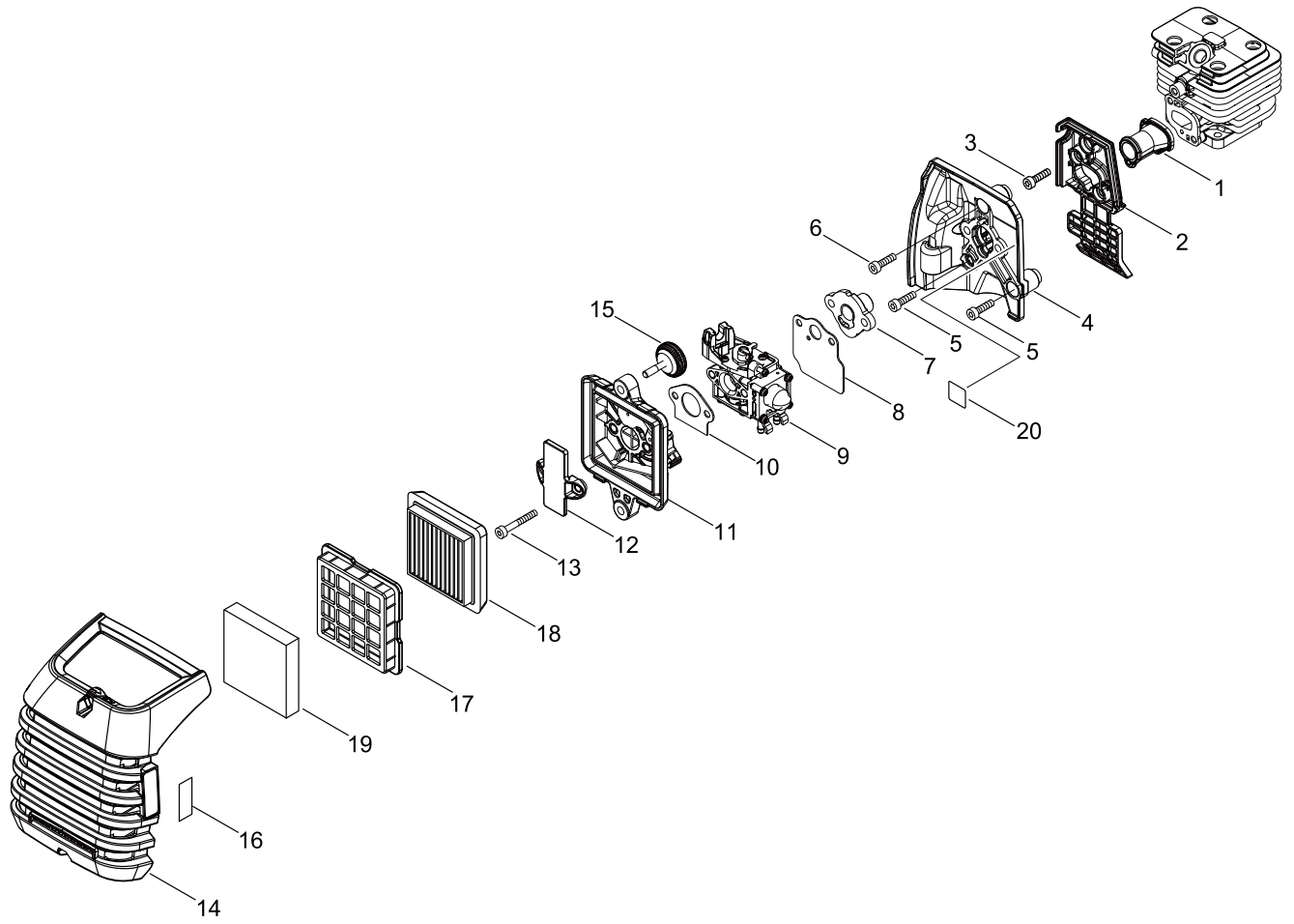

AIR CLEANER, CARBURETOR

KEY NO	LV(+)	Part No	Description	Qty	Standard	Comment
1		A202-000300	BELLOWS, INTAKE	1		
2		A206-000040	HOLDER, BELLOWS	1		
3		V805-000150	BOLT, TORX 5	2	TB-5*16 10.9	
4		A209-001010	PLATE, INSULATOR	1		
5		V805-000150	BOLT, TORX 5	2	TB-5*16 10.9	
6		V855-000000	BOLT, TORX 5	1	TB-5*20	
7		A209-001000	PLATE, INSULATOR	1		
8		V103-001890	GASKET,INTAKE	1		
9		A021-004600	CARBURETOR, DIAPHRAGM	1	WYG-9	
10		V103-001900	GASKET,INTAKE	1		
11		P021-051160	CLEANER CASE ASY	1		
12		A244-000320	PLATE, PREVENT	1		
13		V805-000340	BOLT, TORX 5	2	TB-5*60 10.9	
14		A232-001890	LID,CLEANER	1		
15		V299-000290	KNOB,FASTENER	2	1 KNOB M5X0.8	
16		890332-52730	LABEL, CHOKE	1		
17		A227-000050	PLATE, ELEMENT	1		
18		A226-002030	ELEMENT, AIR FILTER	1		
19		A226-002040	ELEMENT, AIR FILTER	1	HP-70	
20		X524-001901	LABEL	1		PURGE BULB (PRIMER)

CARBURETOR

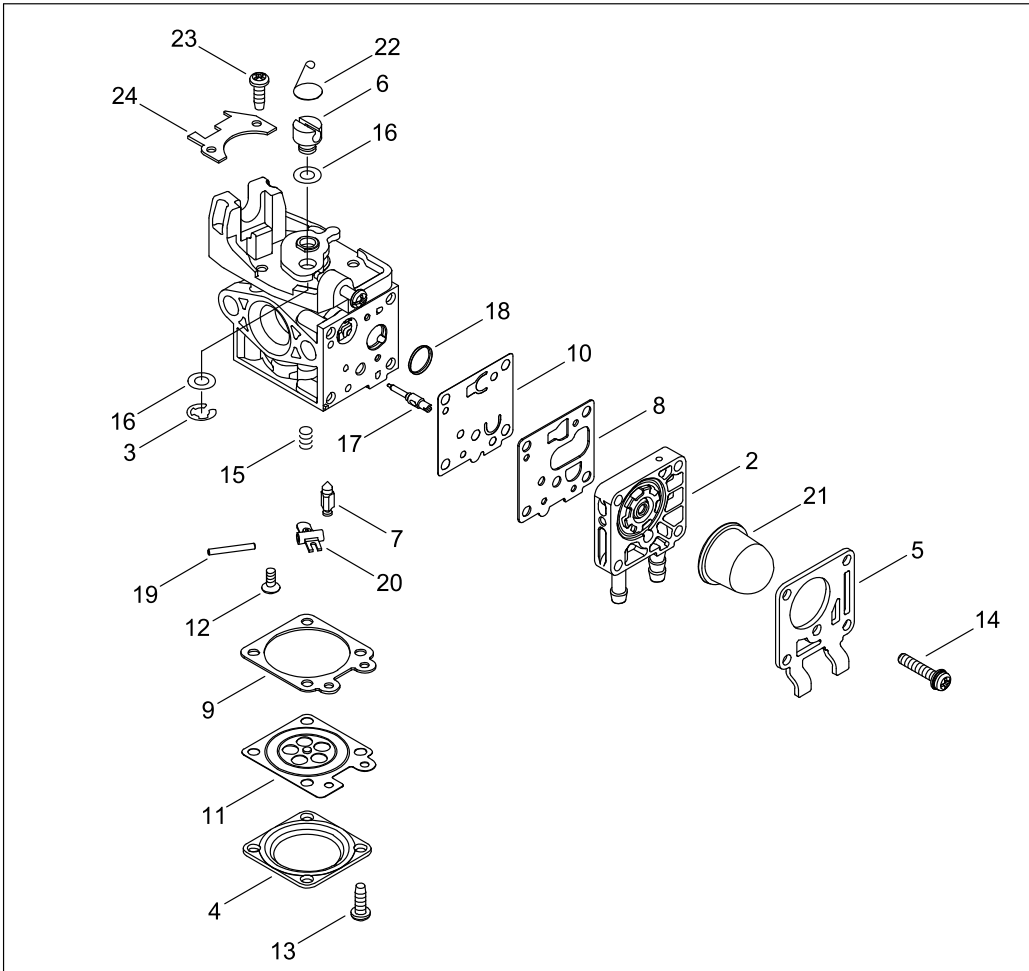

CARBURETOR

KEY NO	LV(+)	Part No	Description	Qty	Standard	Comment
1		A021-004600	CARBURETOR, DIAPHRAGM	1	WYG-9	
2	+	P003-005300	BODY ASSEMBLY, PUMP	1		
3	+	123173-07930	CLIP	1		
4	+	123142-03930	COVER, M. DIAPHRAGM	1		
5	+	P003-004510	COVER, FUEL PUMP	1		
6	+	P003-005850	SWIVEL	1		
7	+	123137-19830	VALVE, INLET NEEDLE	1		
8	+	P003-004530	GASKET, FUEL PUMP	1		
9	+	123140-27230	GASKET,M. DIAPHRAGM	1		
10	+	P003-004540	DIAPHRAGM, FUEL PUMP	1		
11	+	P003-001670	DIAPHRAGM, METERING	1		
12	+	P003-005860	SCREW	1		
13	+	P003-004560	SCREW	4		
14	+	P003-004570	SCREW	4		
15	+	P003-005870	SPRING	1		
16	+	P003-001710	WASHER	2		
17	+	P003-005880	NEEDLE	1		
18	+	123126-10631	SCREEN, INLET	1		
19	+	123138-03930	PIN, METERING LEVER	1		
20	+	P003-001630	LEVER, METERING	1		
21	+	123181-09560	PUMP, PRIMER	1		
22	+	P003-005890	CLIP	1		
23	+	123114-40630	SCREW	3		
24	+	P003-005900	PLATE	1		

FUEL TANK

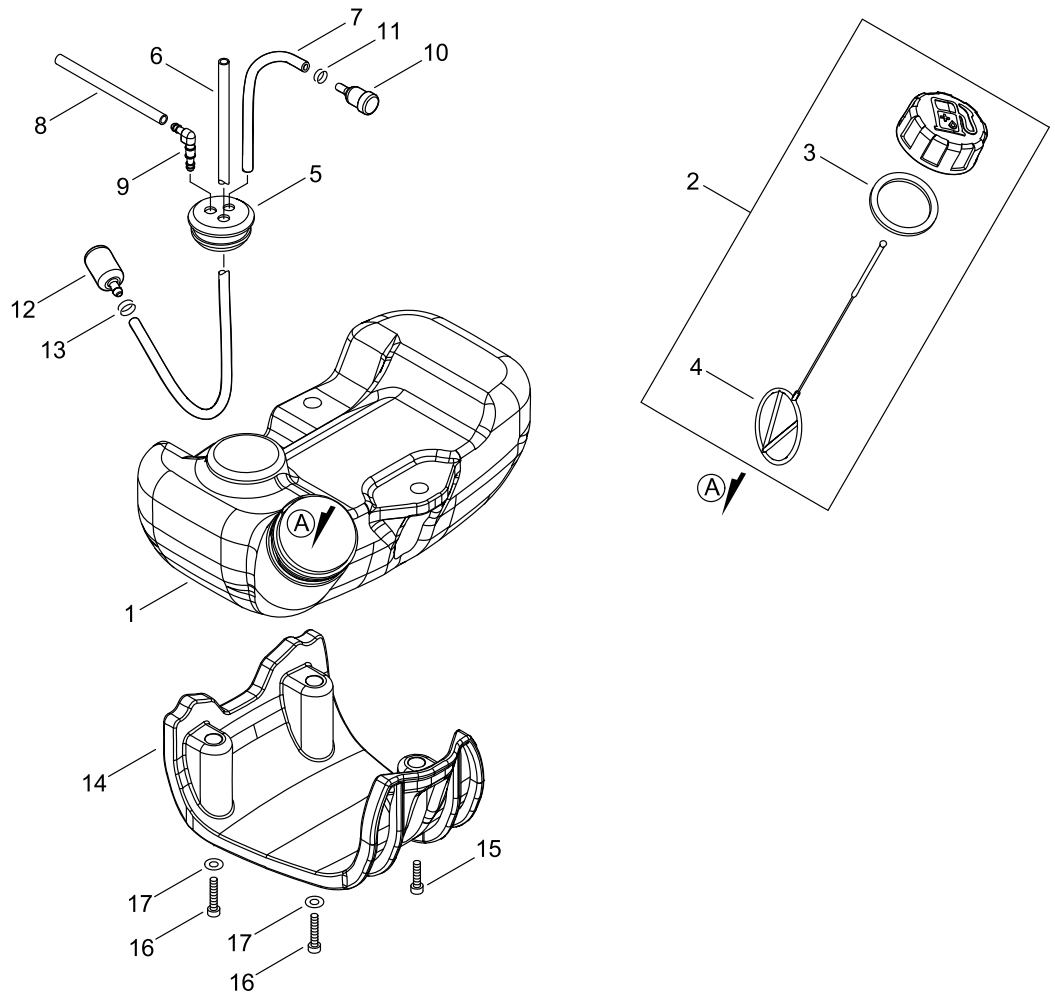

FUEL TANK

KEY NO	LV(+)	Part No	Description	Qty	Standard	Comment
1		A350-002350	TANK, FUEL	1		
2		P021-035680	FUEL CAP ASY	1	T242	
3	+	131016-55830	GASKET, FUEL CAP	1		
4	+	A365-000060	CONNECTOR,CAP	1	L=123	
5		132115-55930	GROMMET, FUEL	1		
6		V471-001230	PIPE	1	3*5*210 NBR	
7		132010-06530	PIPE 3*6* 85	1	3*6* 85	
8		132012-56030	PIPE	1	3*6*80 YL	
9		V186-000500	JOINT,PIPE	1		
10		A356-000031	VALVE,CHECK	1		
11		V490-001230	CLIP	1		
12		A369-000470	STRAINER, FUEL	1		
13		V490-001240	CLIP	1		
14		A175-000040	STAND	1		
15		V805-000160	BOLT, TORX 5	1	TB-5*20 10.9	
16		V805-000170	BOLT, TORX 5	2	TB-5*25 10.9	
17		900602-00005	WASHER 5	2	5.3*10*1	

MUFFLER

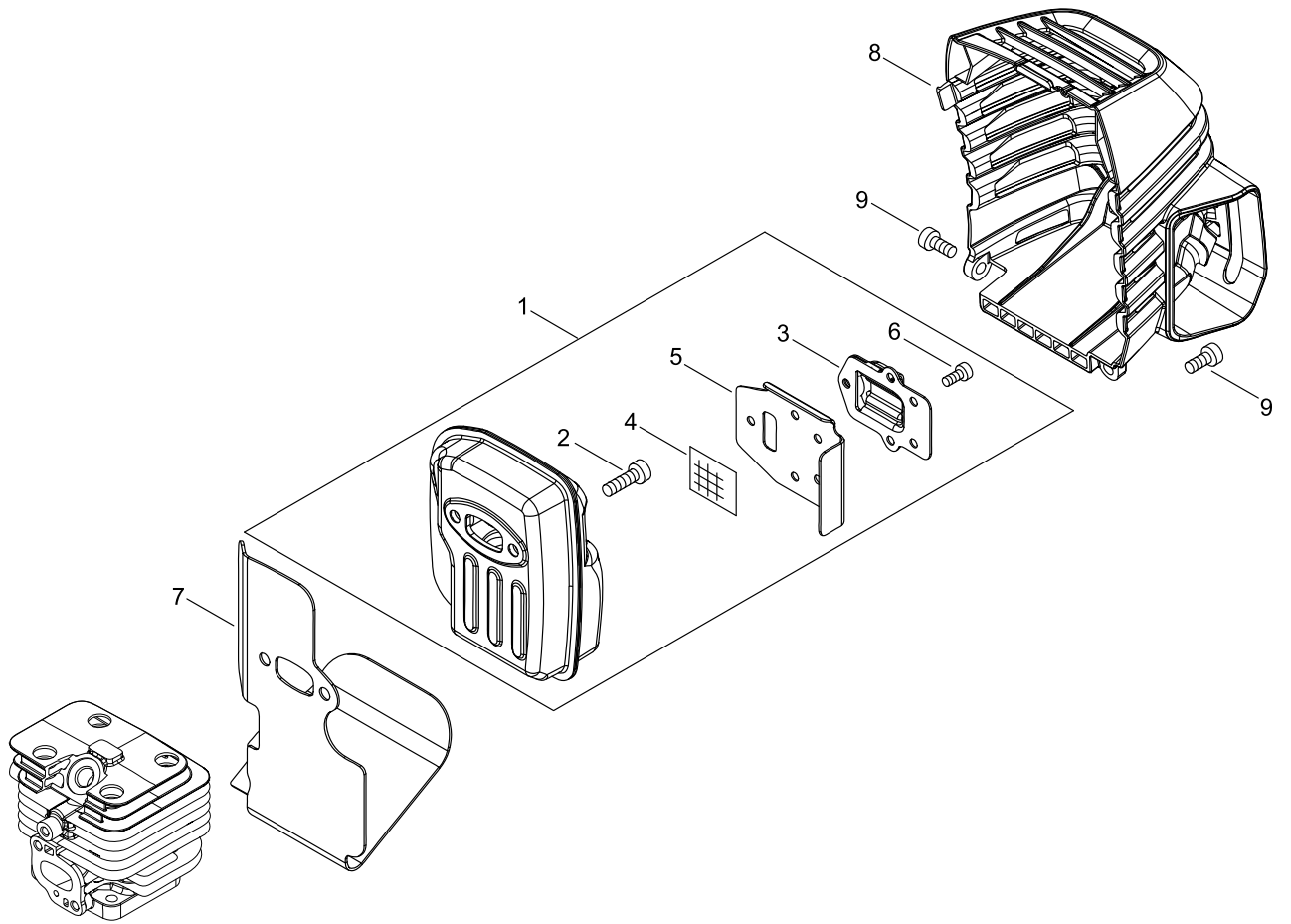

MUFFLER

KEY NO	LV(+)	Part No	Description	Qty	Standard	Comment
1		P021-050900	MUFFLER ASY	1		
2	+	V805-000250	BOLT, TORX 5	2	TB-5*16 12.9	
3	+	A313-002060	GUIDE, EXHAUST	1		
4	+	145862-40630	SCREEN, MUFFLER	1		
5	+	V104-002300	GASKET,EXHAUST	1		
6	+	V804-000030	BOLT, TORX 4	5	TB-4*8 10.9	
7		V104-002310	GASKET,EXHAUST	1		
8		A320-001200	COVER,MUFFLER	1		
9		V805-000140	BOLT, TORX 5	2	TB-5*12 10.9	

RECOIL STARTER, PULLY

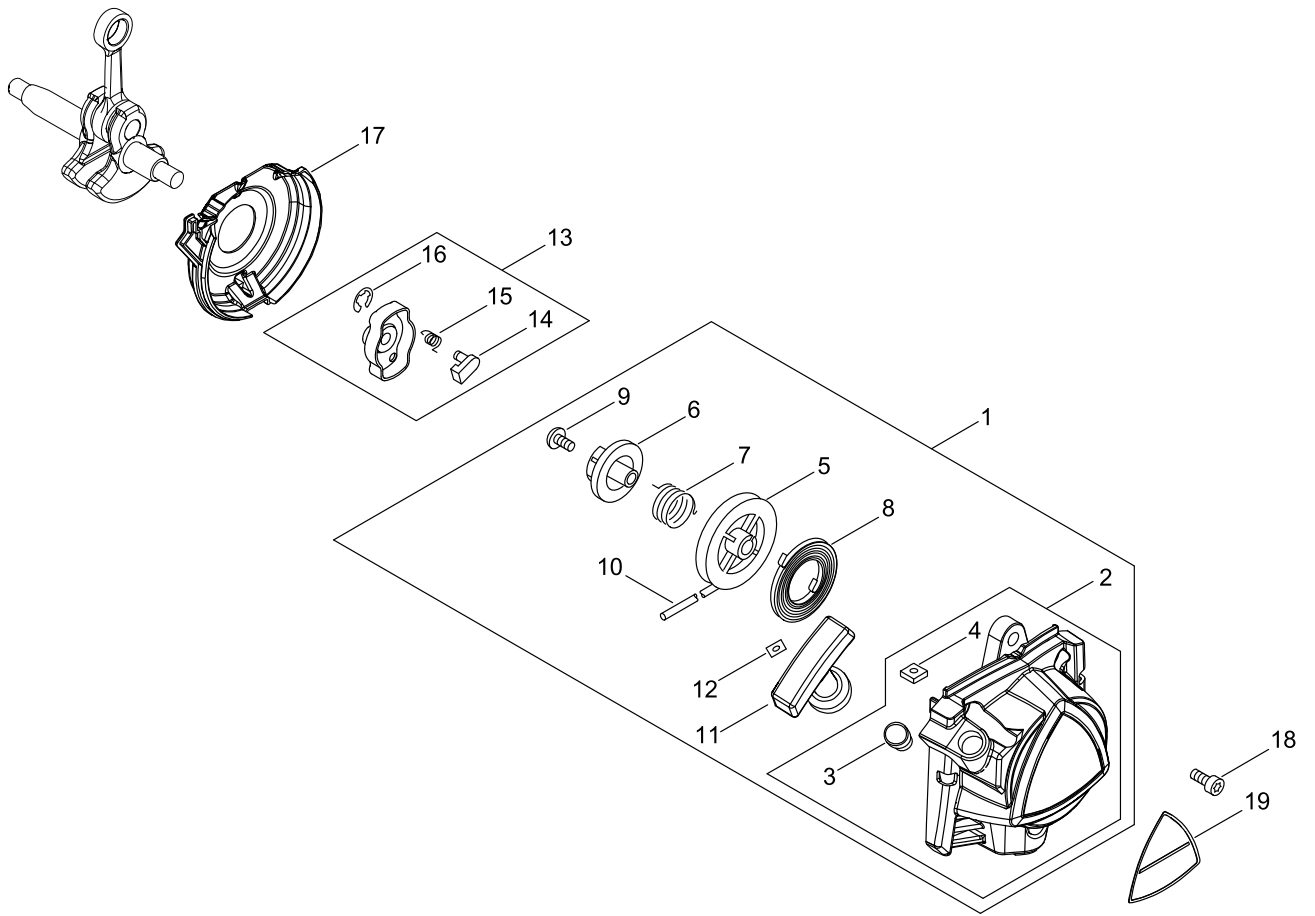

RECOIL STARTER, PULLY

KEY NO	LV(+)	Part No	Description	Qty	Standard	Comment
1		A051-003220	STARTER,RECOIL ASY	1		
2	+	P022-043670	STATER CASE	1		
3	++	177227-42030	GUIDE, ROPE	1		
4	++	900565-00005	NUT	2	5	
5	+	P022-033320	DRUM, STARTER	1		
6	+	P022-033310	PLATE, CAM	1		
7	+	P022-008270	SPRING,DAMPER	1		
8	+	177220-40630	SPRING, REWIND	1		
9	+	177236-61830	SCREW	1		
10	+	P022-022110	ROPE, STARTER	1		
11	+	177228-27030	GRIP, STARTER	1		
12	+	P022-037670	STOPPER, ROPE	1		
13		A052-000180	PULLEY,ASM STARTER	1		
14	+	P022-006850	PAWL, STARTER	2		
15	+	P022-006510	SPRING, RETURN	2		
16	+	P022-002100	E-RING	2	4	
17		A127-000470	COVER,DUST	1		
18		V805-000140	BOLT, TORX 5	3	TB-5*12 10.9	
19		X562-000360	LABEL,SHINDAIWA	1		

GEAR CASE, SHIELD

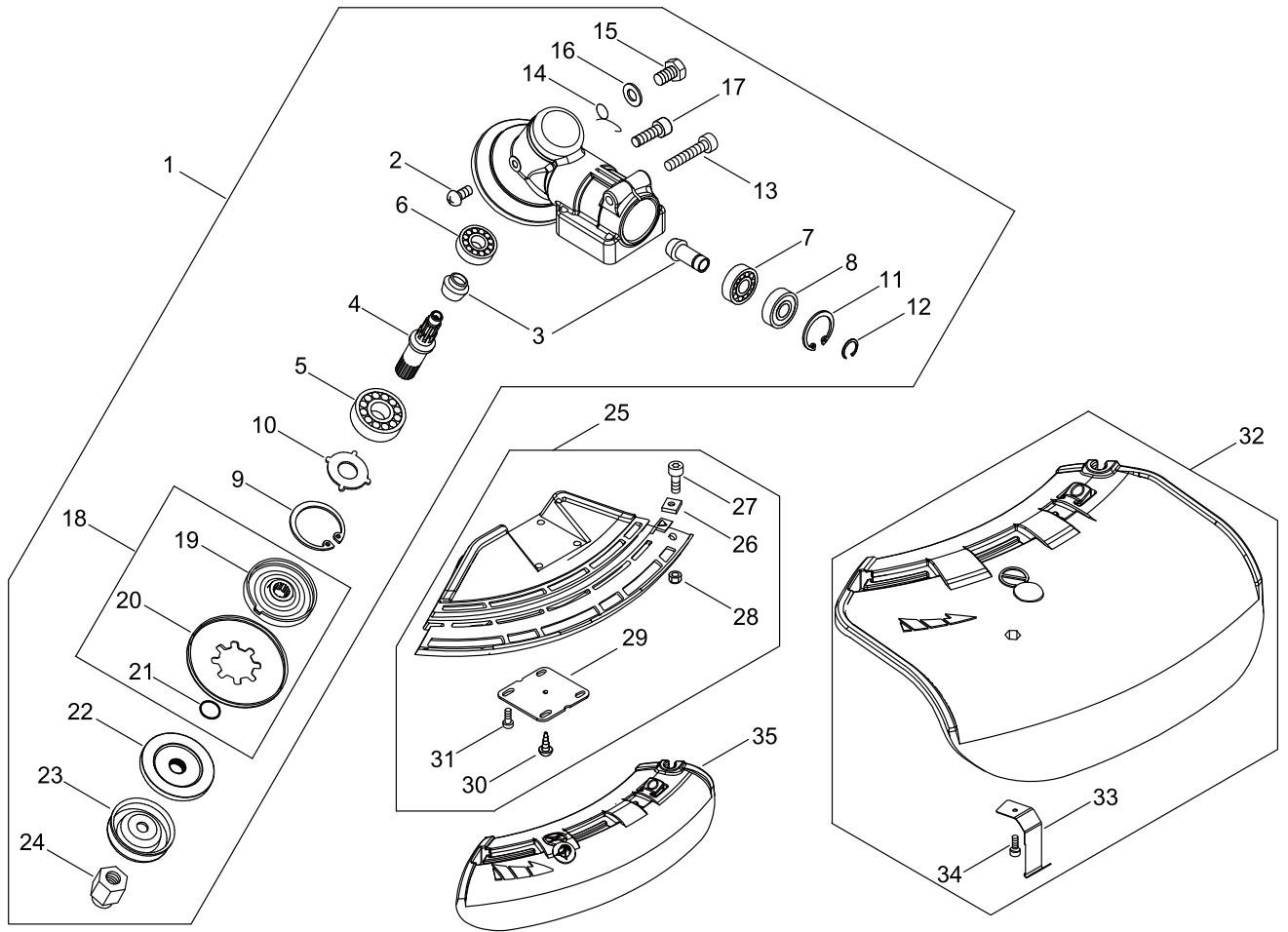

GEAR CASE, SHIELD

KEY NO	LV(+)	Part No	Description	Qty	Standard	Comment
1		P021-050950	GEAR CASE ASY	1		
2	+	900220-04006	SCREW 4*6	1	4*6	
3	+	610300-25531	GEAR SET	1	7S	
4	+	610310-56832	SHAFT, P.T.O.	1	12*10*1	
5	+	900812-06201	BEARING, BALL 6201	1	6201DDU(LLU)	
6	+	94060-00626	BEARING, BALL	1		
7	+	94060-06900	BEARING BALL	1	WEPON BB6900	
8	+	94063-06900	BEARING BALL	1	WEPON BB6900Z	
9	+	900702-00032	CIRCLIP 32	1	CR-32	
10	+	610444-56830	WASHER	1		
11	+	900702-00022	CIRCLIP 22	1	CR-22	
12	+	900706-00010	CIRCLIP 10	1	WR-10	
13	+	V806-000020	BOLT, TORX 6	1	TB-6*25 10.9	
14	+	V452-001310	SPRING,TORSION	1		
15	+	610434-50031	BOLT 8* 8	1	M8*8	
16	+	900603-50008	WASHER	1	8.5*18*0.8T	
17	+	V805-000130	BOLT, TORX 5	1	TB-5*10 10.9	
18	+	610313-52932	FIXTURE,BLADE	1		
19	++	610313-52132	FIXTURE,BLADE	1		
20	++	610352-56830	PLATE, CUP	1		
21	++	900720-00012	O-RING 12	1	P-12	
22	+	610314-52130	PLATE, ADAPTER (L)	1		
23	+	699229-56830	PLATE, COVER	1		
24	+	610320-52130	NUT 10	1		
25		P021-050820	SHIELD BLADE ASY	1		
26	+	900565-00005	NUT	1	5	
27	+	V805-000170	BOLT, TORX 5	1	TB-5*25 10.9	
28	+	900562-00005	NUT, LOCK	1	5	
29	+	C552-000200	PLATE, SHIELD	1		
30	+	91316-04010	SCREW	1	M4*10	
31	+	V805-000260	BOLT, TORX 5	4	TB5*25 10.9	
32		P021-042900	SHIELD ASY, BLADE	1		
33	+	C554-000030	KNIFE, CORD	1	17INCH	
34	+	V805-000150	BOLT, TORX 5	1	TB-5*16 10.9	
35		C550-000541	SHIELD, BLADE	1		

MAIN PIPE, HANDLE

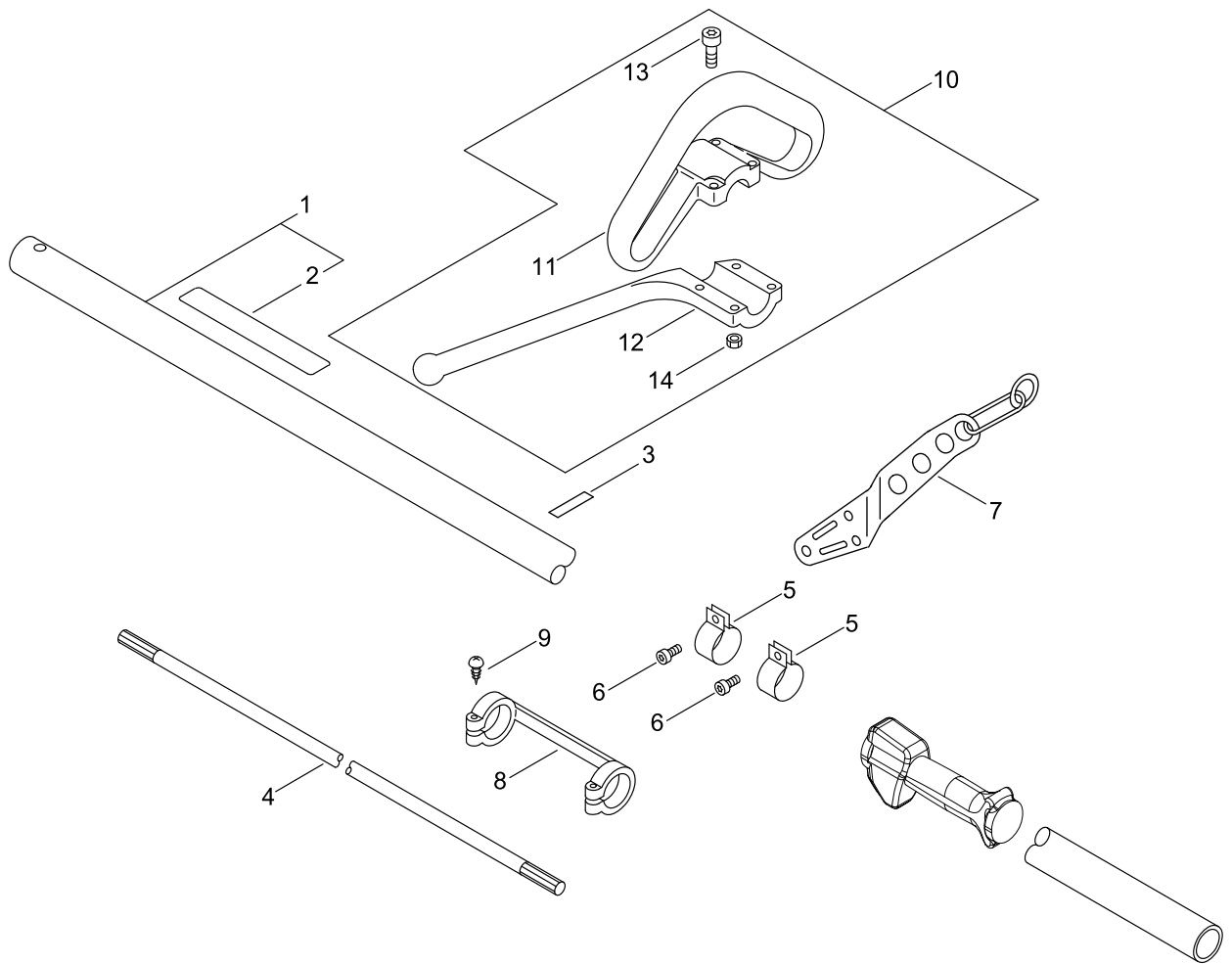

MAIN PIPE, HANDLE

KEY NO	LV(+)	Part No	Description	Qty	Standard	Comment
1		P021-049000	MAIN PIPE ASY	1		
2	+	890617-43130	LABEL,CAUTION	1		
3		890152-04930	LABEL, CAUTION	1		
4		C504-000050	SHAFT,DRIVE	1	7*1540	
5		V495-001010	BAND	2		
6		V805-000140	BOLT, TORX 5	2	TB-5*12 10.9	
7		C624-000020	HANGER,HARNESS	1		
8		V363-000320	COLLAR,24	1		
9		900253-04025	SCREW 4*25	2	4*25	
10		P021-050970	FRONT HANDLE ASY	1		
11	+	C400-000220	HANDLE,FRONT	1		
12	+	351643-51730	BRACET, HANDLE	1		
13	+	V805-000050	BOLT, TORX 5	4	TB-5*30 10.9	
14	+	900500-00005	NUT 5	4	5	

THROTTLE

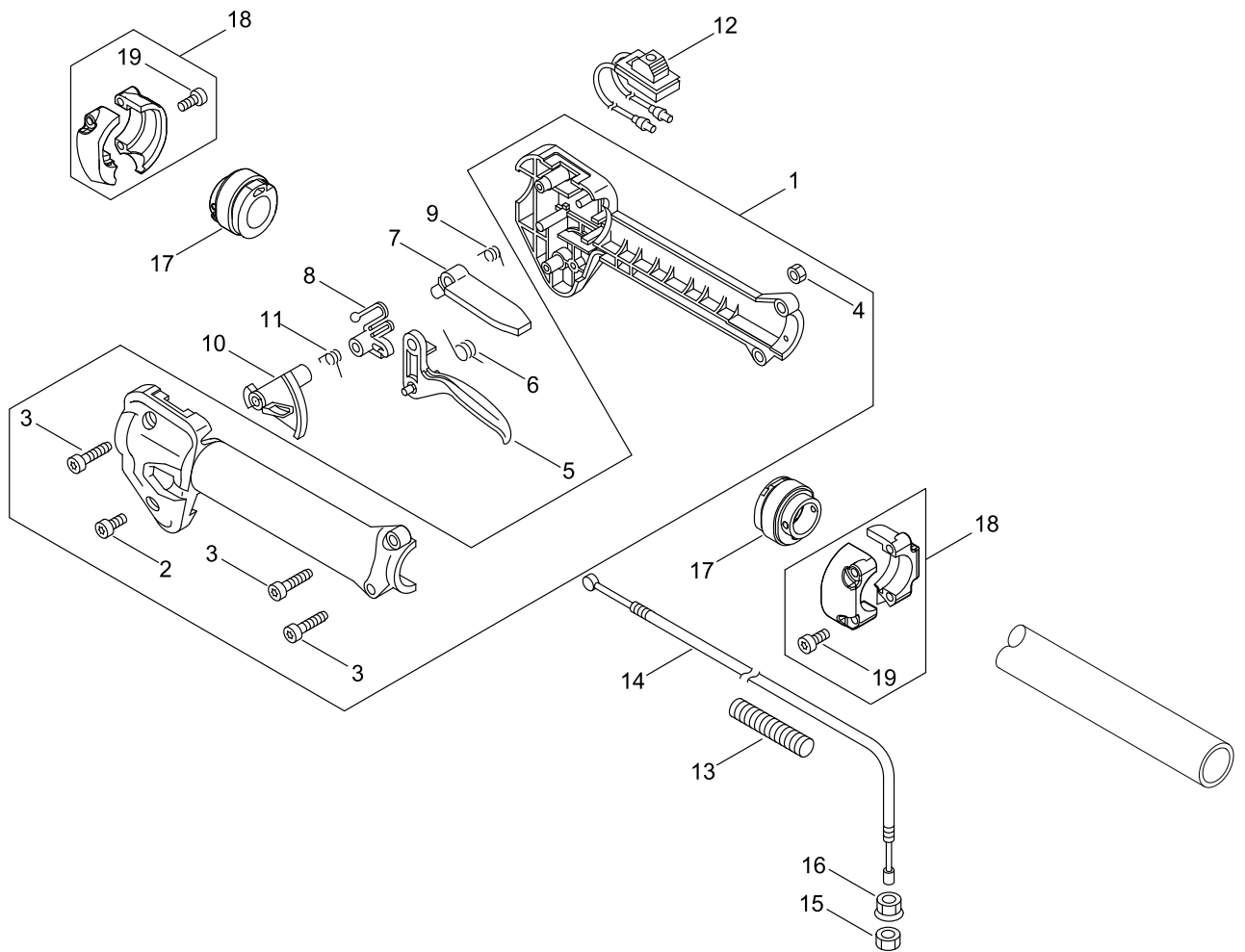

THROTTLE

KEY NO	LV(+)	Part No	Description	Qty	Standard	Comment
1		P021-050980	THROTTLE BRACKET SET	1		
2	+	V805-000060	BOLT, TORX 5	1	TB-5*35 10.9	
3	+	V805-000170	BOLT, TORX 5	3	TB-5*25 10.9	
4	+	900500-00005	NUT 5	4	5	
5		C450-000780	TRIGGER,THROTTLE	1		
6		178043-42230	SPRING, THR. RETURN	1		
7		C460-000370	LOCKOUT,THROTTLE	1		
8		C461-000000	LATCH,THROTTLE	1		
9		178013-52630	SPRING, THR. LOCK	1		
10		C461-000110	LATCH,THROTTLE	1		
11		V452-000120	SPRING,TORSION	1		
12		A440-002800	SWITCH, ON OFF	1		
13		V475-008930	TUBE	1		
14		V430-004940	CABLE,BOWDEN	1		
15		900502-00006	NUT 6 (3N)	1	3N6	
16		900518-00006	NUT, FLANGE	1	6	
17		V420-000960	CUSHION	2		
18		P021-050990	HANDLE FIXTURE ASY	2		
19	+	V805-000170	BOLT, TORX 5	4	TB-5*25 10.9	

ACCESSORIES

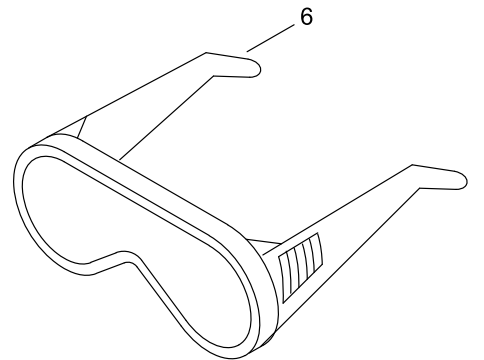
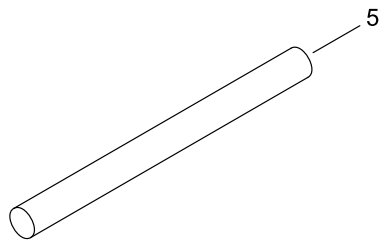
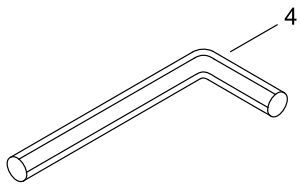
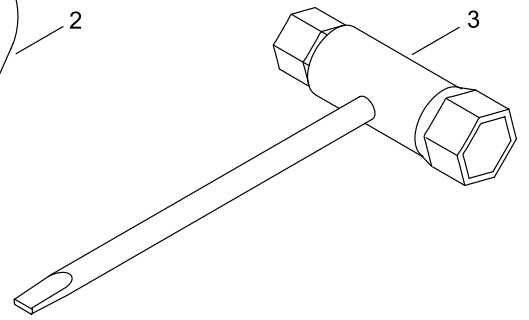
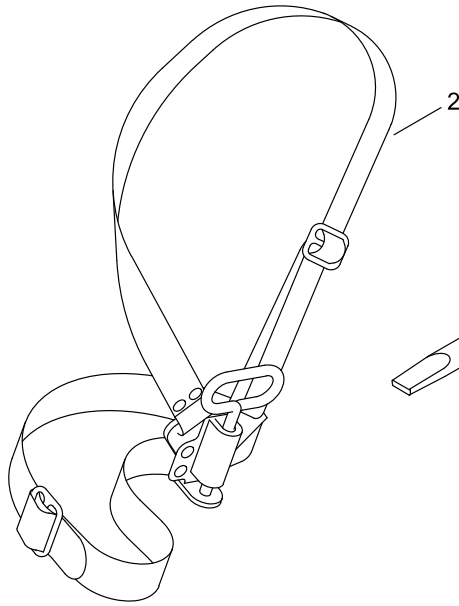
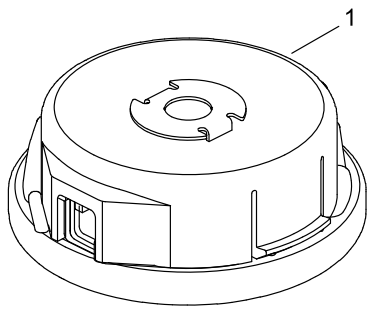

ACCESSORIES

KEY NO	LV(+)	Part No	Description	Qty	Standard	Comment
1		X047-000270	CUTTER,ASM LINE	1	F4/10 M10L	
2		301001-46731	HARNESS, SHOULDER	1	L1910,L1550	
3		895415-66630	WRENCH, SPCKET	1		
4		X605-000170	TOOL,L WRENCH	1		
5		X606-000080	TOOL,BAR	1	5*120	
6		X690-000080	GOGGLE	1	SI CHINA, Z87.1	

NYLON LINE CUTTER

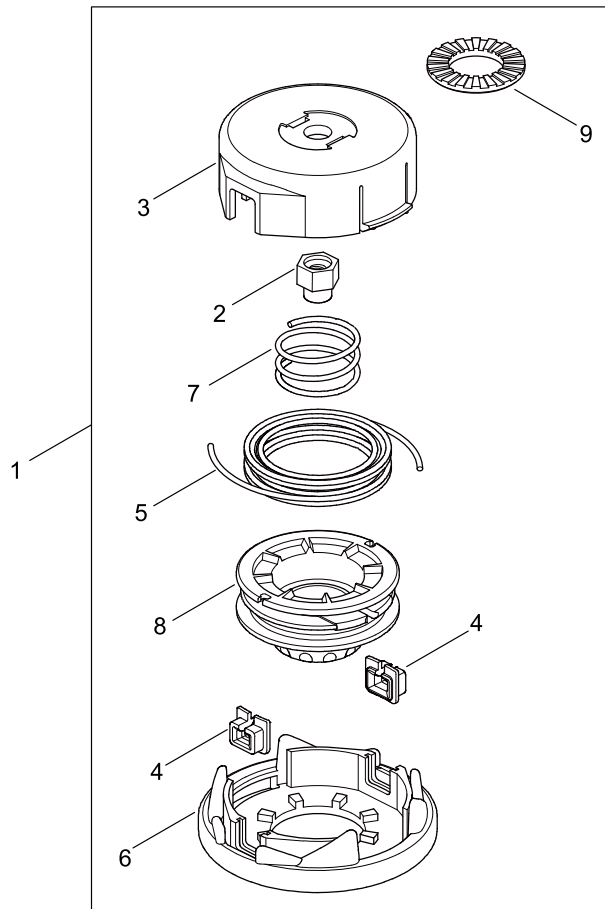

NYLON LINE CUTTER

KEY NO	LV(+)	Part No	Description	Qty	Standard	Comment
1		X047-000270	CUTTER,ASM LINE	1	F4/10 M10L	
2	+	P022-001220	NUT	1		
3	+	P022-003310	HOUSING	1		
4	+	P022-000710	EYELET	2	T4	
5	+	P022-006190	NYLON CODE	1	3.0*2M	
6	+	P022-003330	COVER	1		
7	+	P022-001250	SPRING	1	DS-3/10	
8	+	P022-001260	BOBBIN	1	DS-3/10	
9	+	P022-022050	WASHER	1		

NUMERICAL PARTS INDEX

Part No	Part description	Page	Part No	Part description	Page	Part No	Part description	Page
100013-3-5430	PIN, PISTON	2	177228-2-7030	GRIP, STARTER	18	900502-0-0006	NUT 6 (3N)	24
100014-5-3630	SPACER, PISTON PIN	2	177236-6-1830	SCREW	18	900515-0-0008	NUT, FLANGE 8	6
100015-0-3931	CIRCLIP, PISTON PIN	2	178013-5-2630	SPRING, THR. LOCK	24	900518-0-0006	NUT, FLANGE	24
100142-1-2330	KEY, WOODRUFF	6	178043-4-2230	SPRING, THR. RETURN	24	900562-0-0005	NUT, LOCK	20
100212-4-2031	OILSEAL	4	301001-4-6731	HARNES, SHOULDER	26	900565-0-0005	NUT	18
123114-4-0630	SCREW	12	351643-5-1730	BRACET, HANDLE	22	900565-0-0005	NUT	20
123126-1-0631	SCREEN, INLET	12	610300-2-5531	GEAR SET	20	900602-0-0005	WASHER 5	14
123137-1-9830	VALVE, INLET NEEDLE	12	610310-5-6832	SHAFT, P.T.O.	20	900603-5-0008	WASHER	20
123138-0-3930	PIN, METERING LEVER	12	610313-5-2132	FIXTURE, BLADE	20	900701-0-0012	CIRCLIP 12	8
123140-2-7230	GASKET, M. DIAPHRAGM	12	610313-5-2932	FIXTURE, BLADE	20	900702-0-0022	CIRCLIP 22	20
123142-0-3930	COVER, M. DIAPHRAGM	12	610314-5-2130	PLATE, ADAPTER (L)	20	900702-0-0028	CIRCLIP 28	8
123173-0-7930	CLIP	12	610320-5-2130	NUT 10	20	900702-0-0032	CIRCLIP 32	20
123181-0-9560	PUMP, PRIMER	12	610352-5-6830	PLATE, CUP	20	900702-0-0042	CIRCLIP 42	8
131016-5-5830	GASKET, FUEL CAP	14	610434-5-0031	BOLT 8* 8	20	900706-0-0010	CIRCLIP 10	20
132010-0-6530	PIPE 3*6* 85	14	610444-5-6830	WASHER	20	900720-0-0012	O-RING 12	20
132012-5-6030	PIPE	14	699229-5-6830	PLATE, COVER	20	900800-3-6001	BEARING, BALL 6001	4
132115-5-5930	GROMMET, FUEL	14	890152-0-4930	LABEL, CAUTION	22	900807-0-6001	BEARING, BALL 6001	8
145862-4-0630	SCREEN, MUFFLER	16	890332-5-2730	LABEL, CHOKE	10	900810-3-6000	BEARING, BALL	4
156110-0-4920	BUSHING	6	890617-4-3130	LABEL, CAUTION	22	900812-0-6201	BEARING, BALL 6201	20
175046-5-6030	SHAFT, CLUTCH	8	895415-6-6630	WRENCH, SPCKET	26	91316-04-010	SCREW	20
175048-0-5530	WASHER (I)	8	900220-0-4006	SCREW 4*6	20	94060-00-626	BEARING, BALL	20
175049-5-6030	WASHER	8	900253-0-4025	SCREW 4*25	22	94060-06-900	BEARING BALL	20
177220-4-0630	SPRING, REWIND	18	900500-0-0005	NUT 5	22	94063-06-900	BEARING BALL	20
177227-4-2030	GUIDE, ROPE	18	900500-0-0005	NUT 5	24	A011-00-1460	CRANKSHAFT, ASY	2

NUMERICAL PARTS INDEX

Part No	Part description	Page	Part No	Part description	Page	Part No	Part description	Page
A021-00-4600	CARBURETOR, DIAPHRAGM	10	A369-00-0470	STRAINER, FUEL	14	P003-00-1710	WASHER	12
A021-00-4600	CARBURETOR, DIAPHRAGM	12	A409-00-1320	ROTOR, MAGNETO	6	P003-00-4510	COVER, FUEL PUMP	12
A051-00-3220	STARTER,RECOIL ASY	18	A411-00-1710	COIL, IGNITION	6	P003-00-4530	GASKET, FUEL PUMP	12
A052-00-0180	PULLEY,ASM STARTER	18	A413-00-0090	BOOT	8	P003-00-4540	DIAPHRAGM, FUEL PUMP	12
A101-00-0010	RING,PISTON	2	A425-00-0060	SPARKPLUG	6	P003-00-4560	SCREW	12
A127-00-0470	COVER,DUST	18	A426-00-0010	TERMINAL, SPARKPLUG	6	P003-00-4570	SCREW	12
A130-00-2330	CYLINDER	2	A427-00-0220	CAP,SPARK PLUG	6	P003-00-5300	BODY ASSEMBLY, PUMP	12
A160-00-3290	COVER,CYLINDER	2	A440-00-2800	SWITCH, ON OFF	24	P003-00-5850	SWIVEL	12
A172-00-3140	COVER,FAN	8	A553-00-0190	ARM, CLUTCH	8	P003-00-5860	SCREW	12
A175-00-0040	STAND	14	A556-00-1750	DRUM, CLUTCH	8	P003-00-5870	SPRING	12
A202-00-0300	BELLOWS, INTAKE	10	A575-00-0690	FIXTURE, MAIN PIPE	8	P003-00-5880	NEEDLE	12
A206-00-0040	HOLDER, BELLOWS	10	C152-00-1030	CONNECTOR	6	P003-00-5890	CLIP	12
A209-00-1000	PLATE, INSULATOR	10	C400-00-0220	HANDLE,FRONT	22	P003-00-5900	PLATE	12
A209-00-1010	PLATE, INSULATOR	10	C450-00-0780	TRIGGER, THROTTLE	24	P021-03-5680	FUEL CAP ASY	14
A226-00-2030	ELEMENT, AIR FILTER	10	C460-00-0370	LOCKOUT, THROTTLE	24	P021-04-2900	SHIELD ASY, BLADE	20
A226-00-2040	ELEMENT, AIR FILTER	10	C461-00-0000	LATCH,THROTTLE	24	P021-04-9000	MAIN PIPE ASY	22
A227-00-0050	PLATE, ELEMENT	10	C461-00-0110	LATCH,THROTTLE	24	P021-05-0820	SHIELD BLADE ASY	20
A232-00-1890	LID,CLEANER	10	C504-00-0050	SHAFT,DRIVE	22	P021-05-0840	PISTON KIT	2
A244-00-0320	PLATE, PREVENT	10	C550-00-0541	SHIELD, BLADE	20	P021-05-0850	CRANKCASE KIT	4
A313-00-2060	GUIDE, EXHAUST	16	C552-00-0200	PLATE, SHIELD	20	P021-05-0860	CLUTCH ASY	8
A320-00-1200	COVER,MUFFLER	16	C554-00-0030	KNIFE, CORD	20	P021-05-0900	MUFFLER ASY	16
A350-00-2350	TANK, FUEL	14	C624-00-0020	HANGER,HARNESS	22	P021-05-0950	GEAR CASE ASY	20
A356-00-0031	VALVE,CHECK	14	P003-00-1630	LEVER, METERING	12	P021-05-0970	FRONT HANDLE ASY	22
A365-00-0060	CONNECTOR,CAP	14	P003-00-1670	DIAPHRAGM, METERING	12	P021-05-0980	THROTTLE BRACKET SET	24

NUMERICAL PARTS INDEX

Part No	Part description	Page	Part No	Part description	Page	Part No	Part description	Page
P021-05-0990	HANDLE FIXTURE ASY	24	V104-00-2300	GASKET,EXHAUST	16	V805-00-0140	BOLT, TORX 5	2
P021-05-1000	FAN COVER ASY	8	V104-00-2310	GASKET,EXHAUST	16	V805-00-0140	BOLT, TORX 5	16
P021-05-1160	CLEANER CASE ASY	10	V186-00-0500	JOINT,PIPE	14	V805-00-0140	BOLT, TORX 5	18
P022-00-0710	EYELET	28	V299-00-0290	KNOB,FASTENER	10	V805-00-0140	BOLT, TORX 5	22
P022-00-1220	NUT	28	V323-00-0070	WASHER,CIRCULAR 5	6	V805-00-0150	BOLT, TORX 5	8
P022-00-1250	SPRING	28	V363-00-0320	COLLAR,24	22	V805-00-0150	BOLT, TORX 5	10
P022-00-1260	BOBBIN	28	V420-00-0960	CUSHION	24	V805-00-0150	BOLT, TORX 5	20
P022-00-2100	E-RING	18	V430-00-4940	CABLE,BOWDEN	24	V805-00-0160	BOLT, TORX 5	8
P022-00-3310	HOUSING	28	V451-00-1390	SPRING,TENSION	8	V805-00-0160	BOLT, TORX 5	14
P022-00-3330	COVER	28	V452-00-0120	SPRING,TORSION	24	V805-00-0170	BOLT, TORX 5	8
P022-00-6190	NYLON CODE	28	V452-00-1310	SPRING,TORSION	20	V805-00-0170	BOLT, TORX 5	14
P022-00-6510	SPRING, RETURN	18	V471-00-1230	PIPE	14	V805-00-0170	BOLT, TORX 5	20
P022-00-6850	PAWL, STARTER	18	V475-00-7540	TUBE	6	V805-00-0170	BOLT, TORX 5	24
P022-00-8270	SPRING,DAMPER	18	V475-00-8930	TUBE	24	V805-00-0210	BOLT, TORX 5	2
P022-02-2050	WASHER	28	V485-00-2880	LEAD	6	V805-00-0210	BOLT, TORX 5	6
P022-02-2110	ROPE, STARTER	18	V490-00-1230	CLIP	14	V805-00-0220	BOLT, TORX 5	4
P022-03-3310	PLATE, CAM	18	V490-00-1240	CLIP	14	V805-00-0250	BOLT, TORX 5	16
P022-03-3320	DRUM, STARTER	18	V495-00-1010	BAND	22	V805-00-0260	BOLT, TORX 5	20
P022-03-7670	STOPPER, ROPE	18	V503-00-0040	SEAL,OIL 10	4	V805-00-0340	BOLT, TORX 5	10
P022-04-3670	STATER CASE	18	V554-00-0020	BEARING,NEEDLE 9	2	V806-00-0020	BOLT, TORX 6	20
V100-00-0840	GASKET,CYL	2	V804-00-0030	BOLT, TORX 4	16	V855-00-0000	BOLT, TORX 5	10
V102-00-0300	GASKET, CRANKCASE	4	V805-00-0050	BOLT, TORX 5	22	X047-00-0270	CUTTER,ASM LINE	26
V103-00-1890	GASKET,INTAKE	10	V805-00-0060	BOLT, TORX 5	24	X047-00-0270	CUTTER,ASM LINE	28
V103-00-1900	GASKET,INTAKE	10	V805-00-0130	BOLT, TORX 5	20	X524-00-1901	LABEL	10

NUMERICAL PARTS INDEX

Part No	Part description	Page
X562-00-0350	LABEL,SHINDAIWA	2
X562-00-0360	LABEL,SHINDAIWA	18
X605-00-0170	TOOL,L WRENCH	26
X606-00-0080	TOOL,BAR	26
X690-00-0080	GOGGLE	26