

SRM-2620TES/U

Published:07/25/2018

TABLE OF CONTENTS

CYLINDER, PISTON, CRANKSHAFT.....	1
CRANKCASE	3
MAGNETO.....	5
CLUTCH.....	7
AIR CLEANER, CARBURETOR.....	9
CARBURETOR.....	11
FUEL TANK.....	13
MUFFLER	15
RECOIL STARTER, PULLY	17
GEAR CASE, SHIELD.....	19
MAIN PIPE, HANDLE.....	21
THROTTLE	23
ACCESSORIES	25
NYLON LINE CUTTER.....	27

CYLINDER, PISTON, CRANKSHAFT

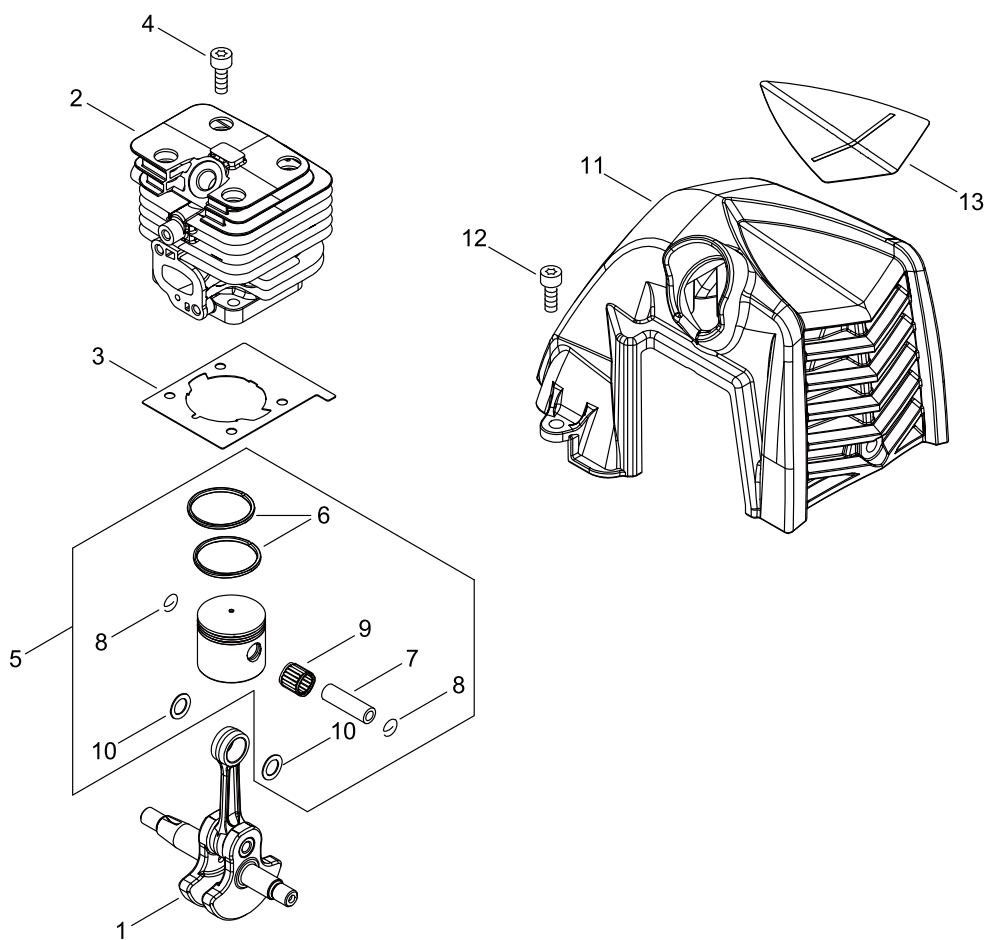

CYLINDER, PISTON, CRANKSHAFT

KEY NO	LV(+)	Part No	Description	Qty	Standard	Comment
1		A011-001460	CRANKSHAFT,ASY	1		
2		A130-002330	CYLINDER	1		
3		V100-000840	GASKET,CYL	1		
4		V805-000210	BOLT, TORX 5	4	TB-5*20 12.9	
5		P021-050840	PISTON KIT	1		
6	+	A101-000010	RING,PISTON	2		
7	+	100013-35430	PIN, PISTON	1	6*9*27.8	
8	+	100015-03931	CIRCLIP, PISTON PIN	2		
9	+	V554-000020	BEARING,NEEDLE 9	1	KTV-91212EG14-B2	
10	+	100014-53630	SPACER, PISTON PIN	2		
11		A160-003280	COVER,CYLINDER	1		
12		V805-000140	BOLT, TORX 5	2	TB-5*12 10.9	
13		X547-002990	LABEL,ECHO	1		

CRANKCASE

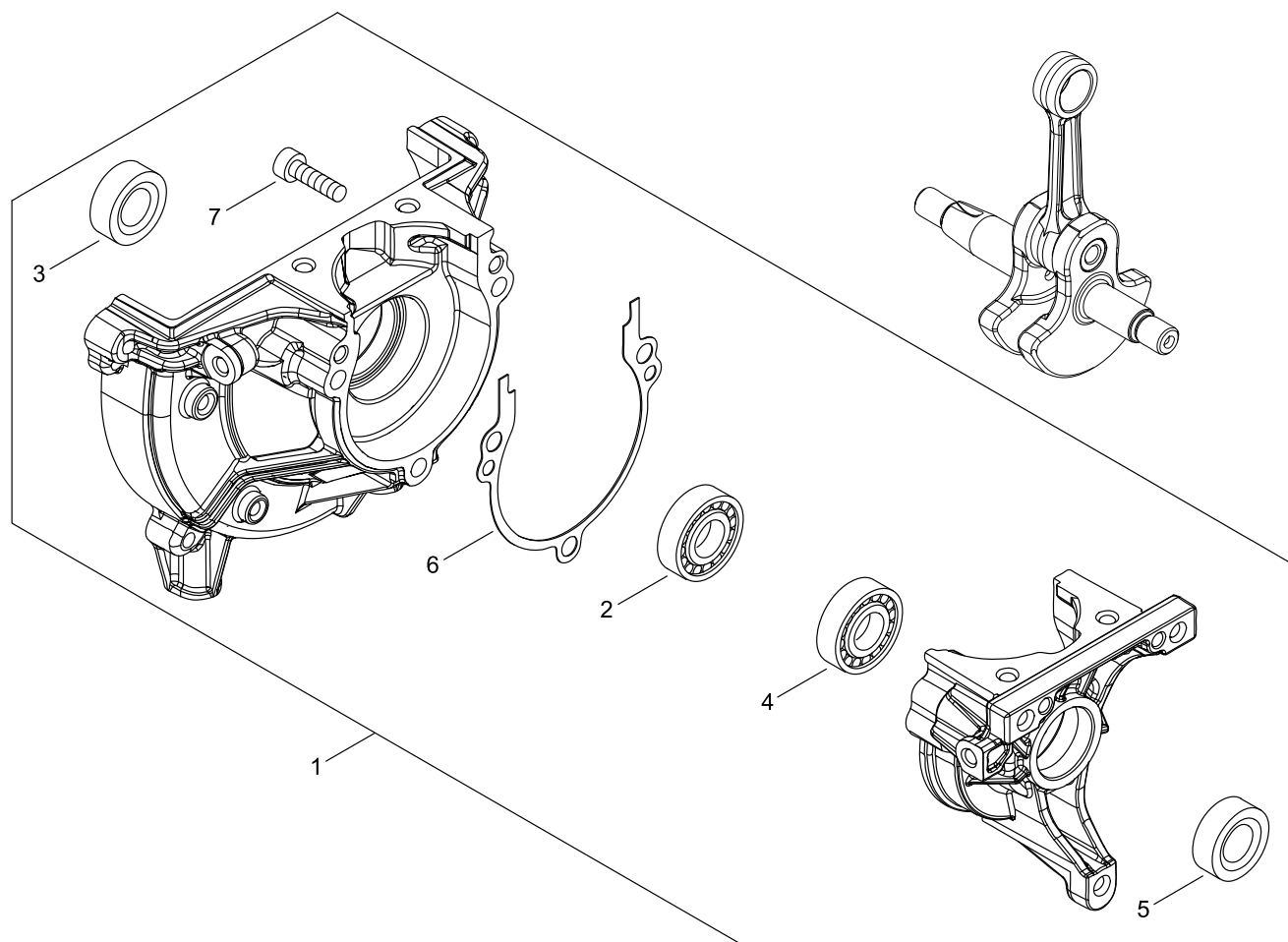

CRANKCASE

KEY NO	LV(+)	Part No	Description	Qty	Standard	Comment
1		P021-050850	CRANKCASE KIT	1		
2	+	900800-36001	BEARING, BALL 6001	1	6001/C3	
3	+	100212-42031	OILSEAL	1	ISCD 12*22*4.5	
4	+	900810-36000	BEARING, BALL	1	6000	
5	+	V503-000040	SEAL,OIL 10	1	ISCD 10*20*5F	
6	+	V102-000300	GASKET,CRANKCASE	1		
7	+	V805-000220	BOLT, TORX 5	3	TB-5*25 12.9	

MAGNETO

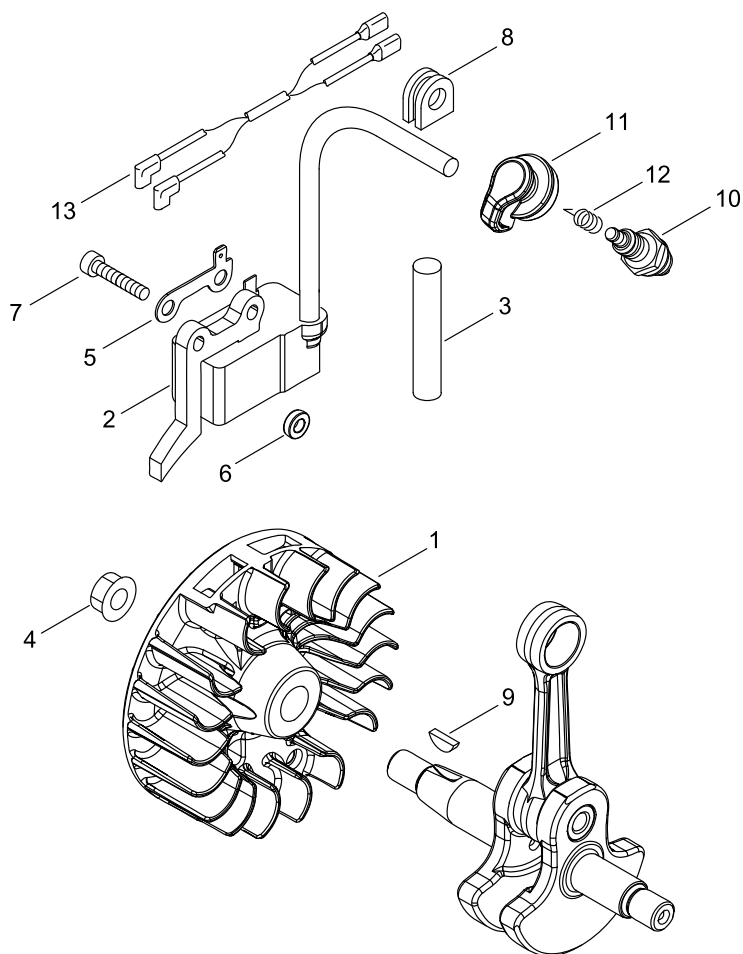

MAGNETO

KEY NO	LV(+)	Part No	Description	Qty	Standard	Comment
1		A409-001320	ROTOR, MAGNETO	1		
2		A411-001710	COIL, IGNITION	1		
3		V475-007540	TUBE	1		
4		900515-00008	NUT, FLANGE 8	1	8	
5		C152-001030	CONNECTOR	1		
6		V323-000070	WASHER,CIRCULAR 5	2	5.2*10*3	
7		V805-000210	BOLT, TORX 5	2	TB-5*20 12.9	
8		156110-04920	BUSHING	1		
9		100142-12330	KEY, WOODRUFF	1		
10		A425-000060	SPARKPLUG	1	CMR7H	
11		A427-000220	CAP,SPARK PLUG	1		
12		A426-000010	TERMINAL,SPARKPLUG	1		
13		V485-002880	LEAD	1		

CLUTCH

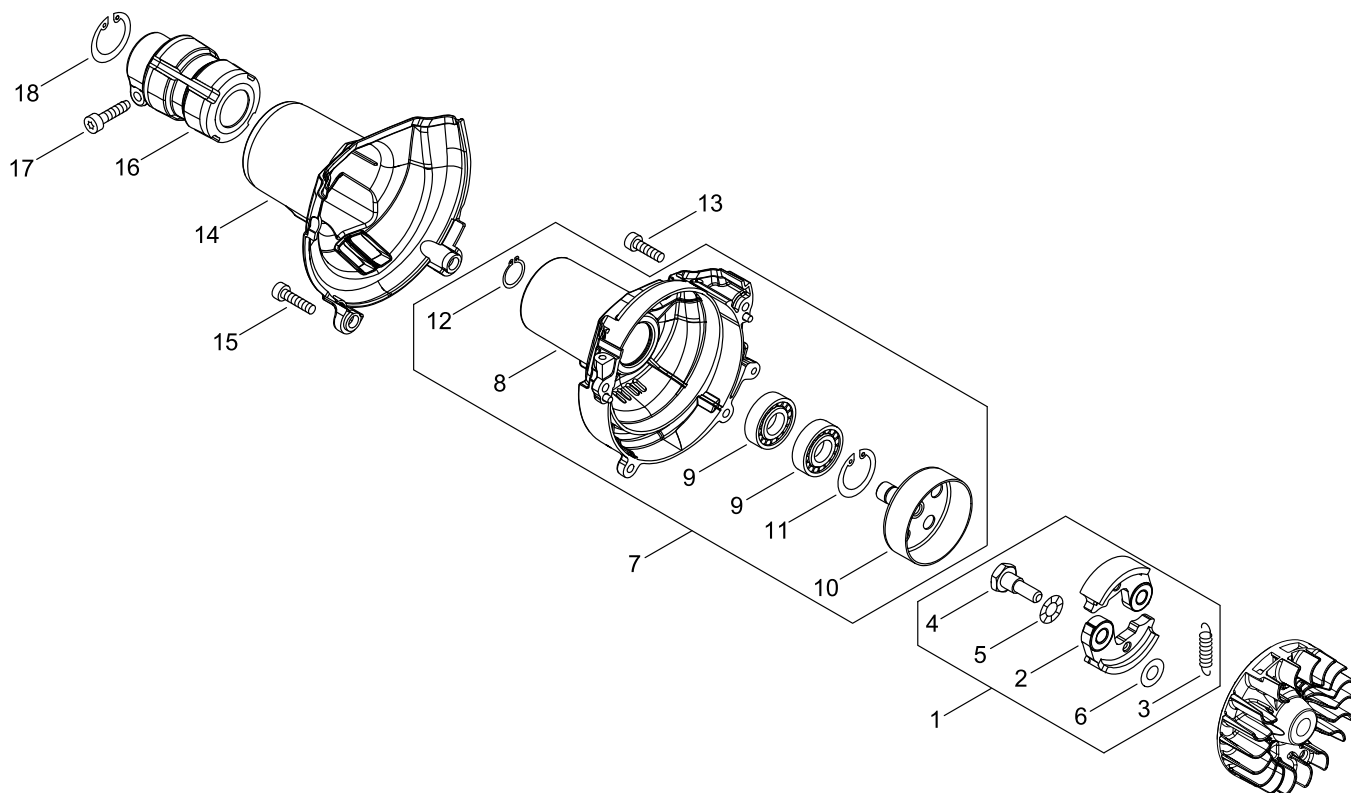

CLUTCH

KEY NO	LV(+)	Part No	Description	Qty	Standard	Comment
1		P021-050860	CLUTCH ASY	1		
2	+	A553-000190	ARM, CLUTCH	2		
3	+	V451-001390	SPRING,TENSION	1	172N/34MM	
4	+	175046-56030	SHAFT, CLUTCH	2		
5	+	175049-56030	WASHER	2	8.5*16*0.5	
6	+	175048-05530	WASHER (I)	2	6.2*19*1.0	
7		P021-051000	FAN COVER ASY	1		
8	+	A172-003140	COVER,FAN	1		
9	+	900807-06001	BEARING, BALL 6001	2	6001V(LB)	
10	+	A556-001750	DRUM, CLUTCH	1		
11	+	900702-00028	CIRCLIP 28	1	CR-28	
12	+	900701-00012	CIRCLIP 12	1	CS-12	
13		V805-000150	BOLT, TORX 5	2	TB-5*16 10.9	
14		A413-000080	BOOT	1		
15		V805-000160	BOLT, TORX 5	2	TB-5*20 10.9	
16		A575-000690	FIXTURE, MAIN PIPE	1		
17		V805-000170	BOLT, TORX 5	1	TB-5*25 10.9	
18		900702-00042	CIRCLIP 42	1	CR-42	

AIR CLEANER, CARBURETOR

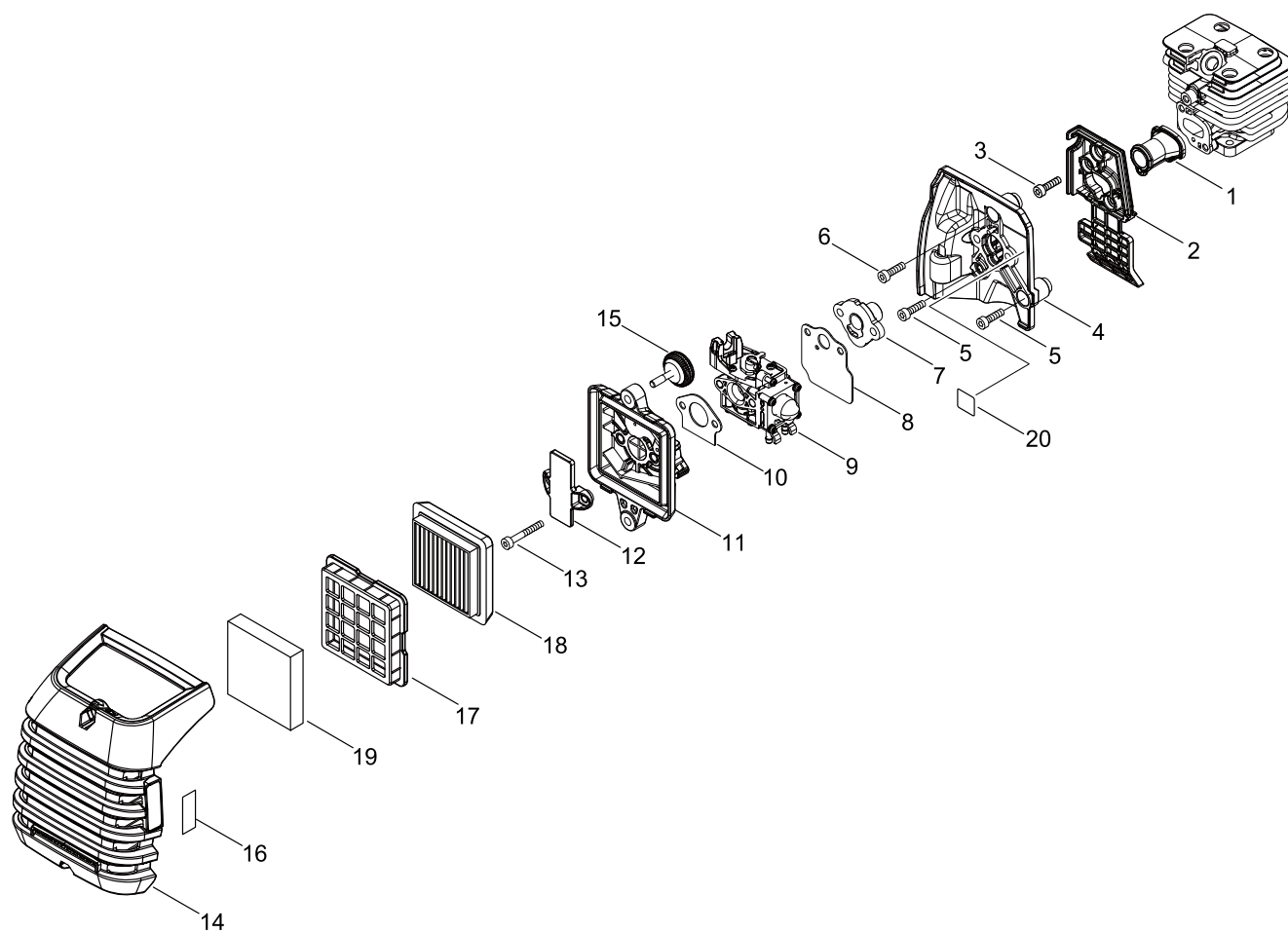

AIR CLEANER, CARBURETOR

KEY NO	LV(+)	Part No	Description	Qty	Standard	Comment
1		A202-000300	BELLOWS, INTAKE	1		
2		A206-000040	HOLDER, BELLOWS	1		
3		V805-000150	BOLT, TORX 5	2	TB-5*16 10.9	
4		A209-001010	PLATE, INSULATOR	1		
5		V805-000150	BOLT, TORX 5	2	TB-5*16 10.9	
6		V855-000000	BOLT, TORX 5	1	TB-5*20	
7		A209-001000	PLATE, INSULATOR	1		
8		V103-001890	GASKET,INTAKE	1		
9		A021-004600	CARBURETOR, DIAPHRAGM	1	WYG-9	
10		V103-001900	GASKET,INTAKE	1		
11		P021-050880	CLEANER CASE ASY	1		
12		A244-000320	PLATE, PREVENT	1		
13		V805-000340	BOLT, TORX 5	2	TB-5*60 10.9	
14		A232-001890	LID,CLEANER	1		
15		V299-000290	KNOB,FASTENER	2	1 KNOB M5X0.8	
16		890332-52730	LABEL, CHOKE	1		
17		A227-000050	PLATE, ELEMENT	1		
18		A226-002030	ELEMENT, AIR FILTER	1		
19		A226-002040	ELEMENT, AIR FILTER	1	HP-70	
20		X524-001901	LABEL	1		PURGE BULB (PRIMER)

CARBURETOR

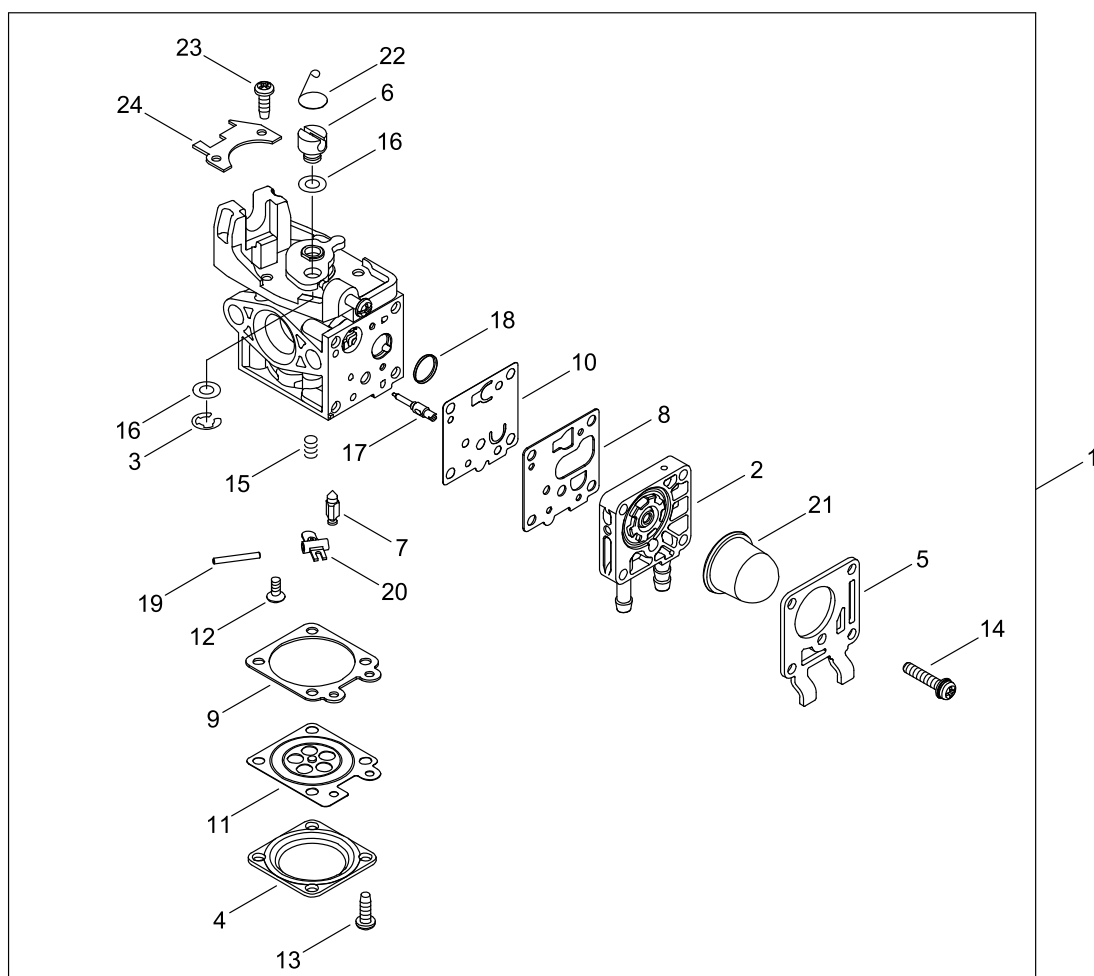

CARBURETOR

KEY NO	LV(+)	Part No	Description	Qty	Standard	Comment
1		A021-004600	CARBURETOR, DIAPHRAGM	1	WYG-9	
2	+	P003-005300	BODY ASSEMBLY, PUMP	1		
3	+	123173-07930	CLIP	1		
4	+	123142-03930	COVER, M. DIAPHRAGM	1		
5	+	P003-004510	COVER, FUEL PUMP	1		
6	+	P003-005850	SWIVEL	1		
7	+	123137-19830	VALVE, INLET NEEDLE	1		
8	+	P003-004530	GASKET, FUEL PUMP	1		
9	+	123140-27230	GASKET,M. DIAPHRAGM	1		
10	+	P003-004540	DIAPHRAGM, FUEL PUMP	1		
11	+	P003-001670	DIAPHRAGM, METERING	1		
12	+	P003-005860	SCREW	1		
13	+	P003-004560	SCREW	4		
14	+	P003-004570	SCREW	4		
15	+	P003-005870	SPRING	1		
16	+	P003-001710	WASHER	2		
17	+	P003-005880	NEEDLE	1		
18	+	123126-10631	SCREEN, INLET	1		
19	+	123138-03930	PIN, METERING LEVER	1		
20	+	P003-001630	LEVER, METERING	1		
21	+	123181-09560	PUMP, PRIMER	1		
22	+	P003-005890	CLIP	1		
23	+	123114-40630	SCREW	3		
24	+	P003-005900	PLATE	1		

FUEL TANK

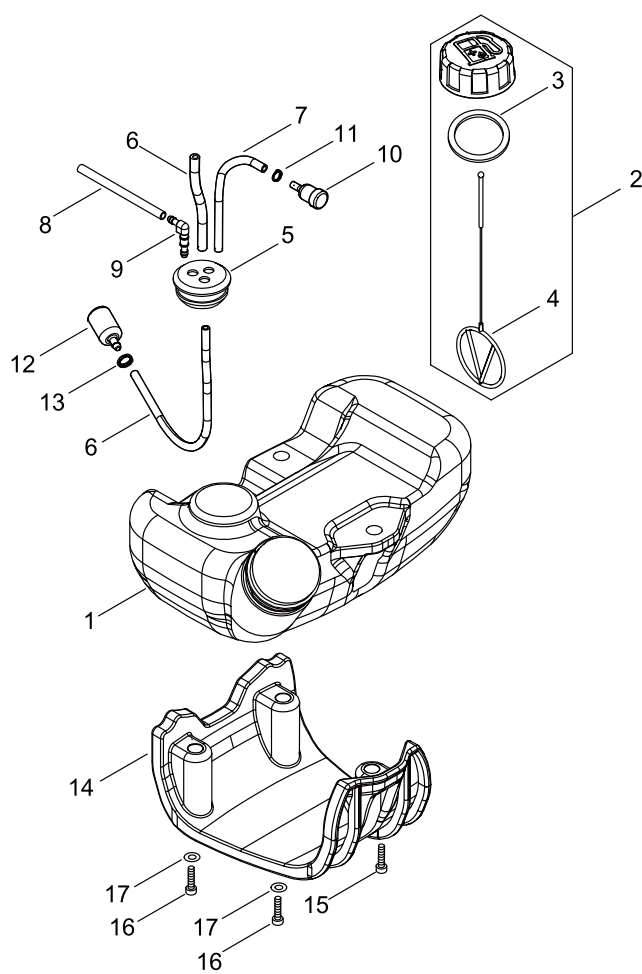

FUEL TANK

KEY NO	LV(+)	Part No	Description	Qty	Standard	Comment
1		A350-002350	TANK, FUEL	1		
2		P021-012210	CAP,FUEL ASY	1		
3	+	131016-55830	GASKET, FUEL CAP	1		
4	+	A365-000060	CONNECTOR,CAP	1	L=123	
5		132115-55930	GROMMET, FUEL	1		
6		V471-001230	PIPE	1	3*5*210 NBR	
7		132010-06530	PIPE 3*6* 85	1	3*6* 85	
8		132012-56030	PIPE	1	3*6*80 YL	
9		V186-000500	JOINT,PIPE	1		
10		131300-56431	VENT ASSEMBLY, FUEL	1		
11		V490-001230	CLIP	1		
12		A369-000470	STRAINER, FUEL	1		
13		V490-001240	CLIP	1		
14		A175-000040	STAND	1		
15		V805-000160	BOLT, TORX 5	1	TB-5*20 10.9	
16		V805-000170	BOLT, TORX 5	2	TB-5*25 10.9	
17		900602-00005	WASHER 5	2	5.3*10*1	

MUFFLER

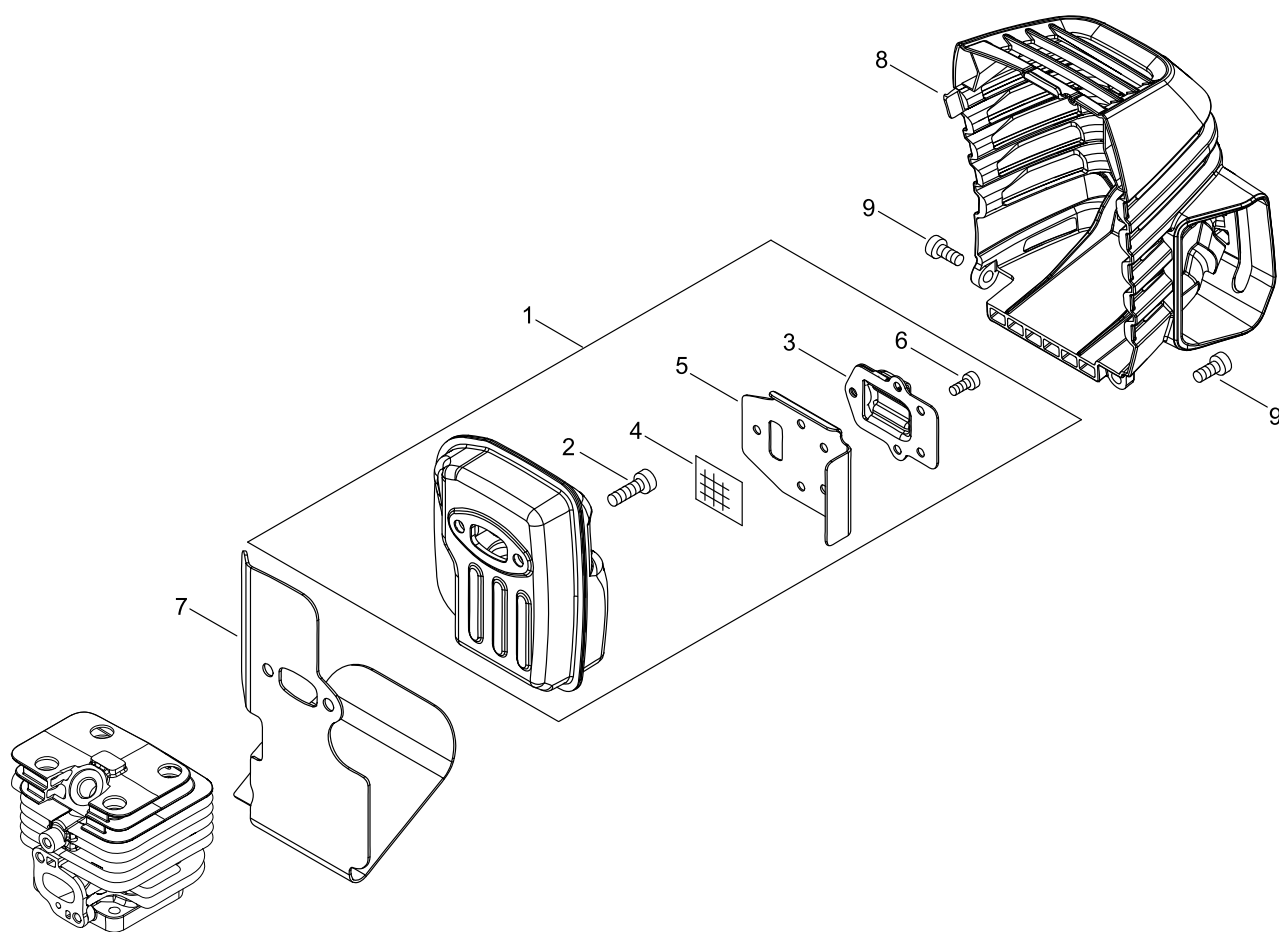

MUFFLER

KEY NO	LV(+)	Part No	Description	Qty	Standard	Comment
1		P021-050900	MUFFLER ASY	1		
2	+	V805-000250	BOLT, TORX 5	2	TB-5*16 12.9	
3	+	A313-002060	GUIDE, EXHAUST	1		
4	+	145862-40630	SCREEN, MUFFLER	1		
5	+	V104-002300	GASKET,EXHAUST	1		
6	+	V804-000030	BOLT, TORX 4	5	TB-4*8 10.9	
7		V104-002310	GASKET,EXHAUST	1		
8		A320-001200	COVER,MUFFLER	1		
9		V805-000140	BOLT, TORX 5	2	TB-5*12 10.9	

RECOIL STARTER, PULLY

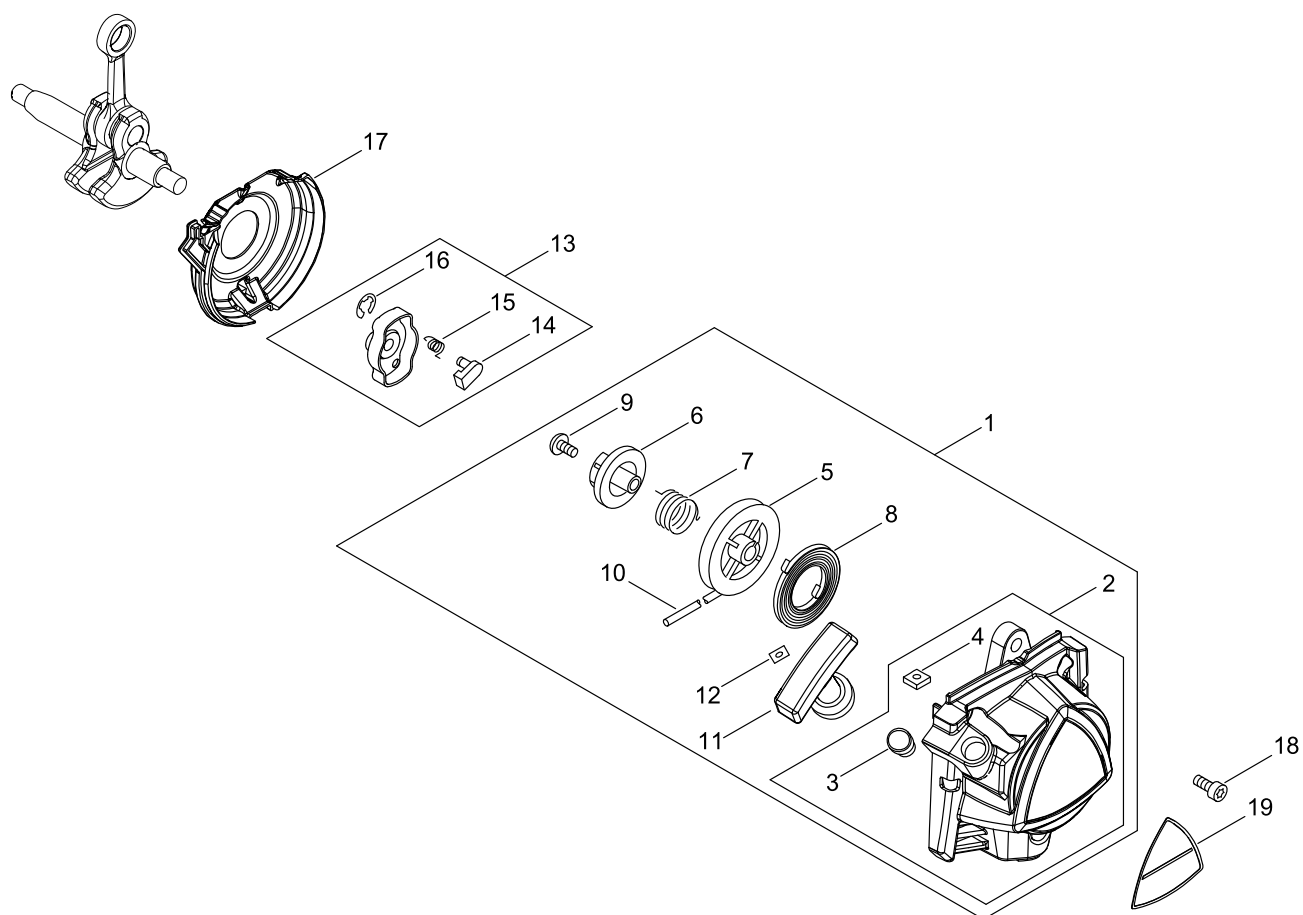

RECOIL STARTER, PULLY

KEY NO	LV(+)	Part No	Description	Qty	Standard	Comment
1		A051-003220	STARTER,RECOIL ASY	1		
2	+	P022-043670	STATER CASE	1		
3	++	177227-42030	GUIDE, ROPE	1		
4	++	900565-00005	NUT	2	5	
5	+	P022-033320	DRUM, STARTER	1		
6	+	P022-033310	PLATE, CAM	1		
7	+	P022-008270	SPRING,DAMPER	1		
8	+	177220-40630	SPRING, REWIND	1		
9	+	177236-61830	SCREW	1		
10	+	P022-022110	ROPE, STARTER	1		
11	+	177228-27030	GRIP, STARTER	1		
12	+	P022-037670	STOPPER, ROPE	1		
13		A052-000180	PULLEY,ASM STARTER	1		
14	+	P022-006850	PAWL, STARTER	2		
15	+	P022-006510	SPRING, RETURN	2		
16	+	P022-002100	E-RING	2	4	
17		A127-000470	COVER,DUST	1		
18		V805-000140	BOLT, TORX 5	3	TB-5*12 10.9	
19		X547-002980	LABEL,ECHO	1		

GEAR CASE, SHIELD

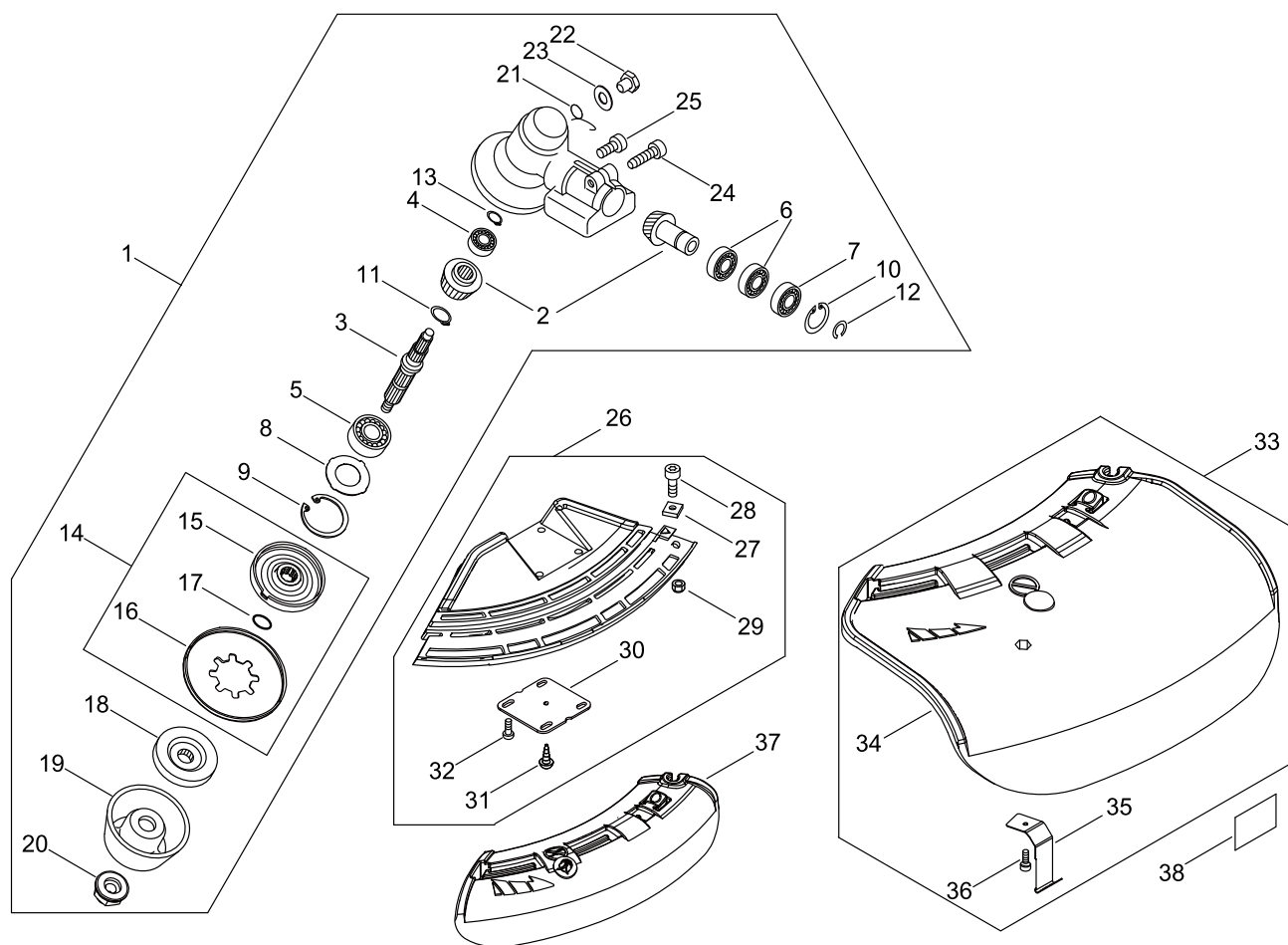

GEAR CASE, SHIELD

KEY NO	LV(+)	Part No	Description	Qty	Standard	Comment
1		P021-051190	GEAR CASE ASY	1		
2	+	V000-000110	GEAR SET, BEVEL	1		
3	+	C534-000940	SHAFT, GEAR	1	M10	
4	+	900810-00629	BEARING, BALL 629	1	629	
5	+	900812-06302	BEARING, BALL	1	BB6302 LLU, DDU	
6	+	900855-06900	BEARING, BALL 6900	2	6900	
7	+	900858-06900	BEARING, BALL 6900Z	1	6900Z	
8	+	V313-000090	WASHER,CIRCULAR 20	1		
9	+	900702-00042	CIRCLIP 42	1	CR-42	
10	+	900702-00022	CIRCLIP 22	1	CR-22	
11	+	900706-00012	CIRCLIP 12	1	WR-12	
12	+	900706-00010	CIRCLIP 10	1	WR-10	
13	+	900701-00009	CIRCLIP 9	1	CS-9	
14	+	C535-000920	FIXTURE, BLADE	1		
15	++	C535-000930	FIXTURE, BLADE	1		
16	++	610352-56830	PLATE, CUP	1		
17	++	900720-00012	O-RING 12	1	P-12	
18	+	610314-52130	PLATE, ADAPTER (L)	1		
19	+	699229-56830	PLATE, COVER	1		
20	+	610320-52130	NUT 10	1		
21	+	V452-001310	SPRING,TORSION	1		
22	+	610434-50031	BOLT 8* 8	1	M8*8	
23	+	900603-50008	WASHER	1	8.5*18*0.8T	
24	+	V806-000020	BOLT, TORX 6	1	TB-6*25 10.9	
25	+	V805-000130	BOLT, TORX 5	1	TB-5*10 10.9	
26		P021-050810	SHIELD BLADE ASY	1		
27	+	900565-00005	NUT	1	5	
28	+	V805-000170	BOLT, TORX 5	1	TB-5*25 10.9	
29	+	900562-00005	NUT, LOCK	1	5	
30	+	C552-000200	PLATE, SHIELD	1		
31	+	91316-04010	SCREW	1	M4*10	
32	+	V805-000260	BOLT, TORX 5	4	TB5*25 10.9	
33		P021-042900	SHIELD ASY, BLADE	1		
34	+	C550-000560	SHIELD, BLADE	1		
35	+	C554-000030	KNIFE, CORD	1	17INCH	
36	+	V805-000150	BOLT, TORX 5	1	TB-5*16 10.9	
37		C550-000541	SHIELD, BLADE	1		
38		X524-005230	LABEL	1	HIGH TORQUE	

MAIN PIPE, HANDLE

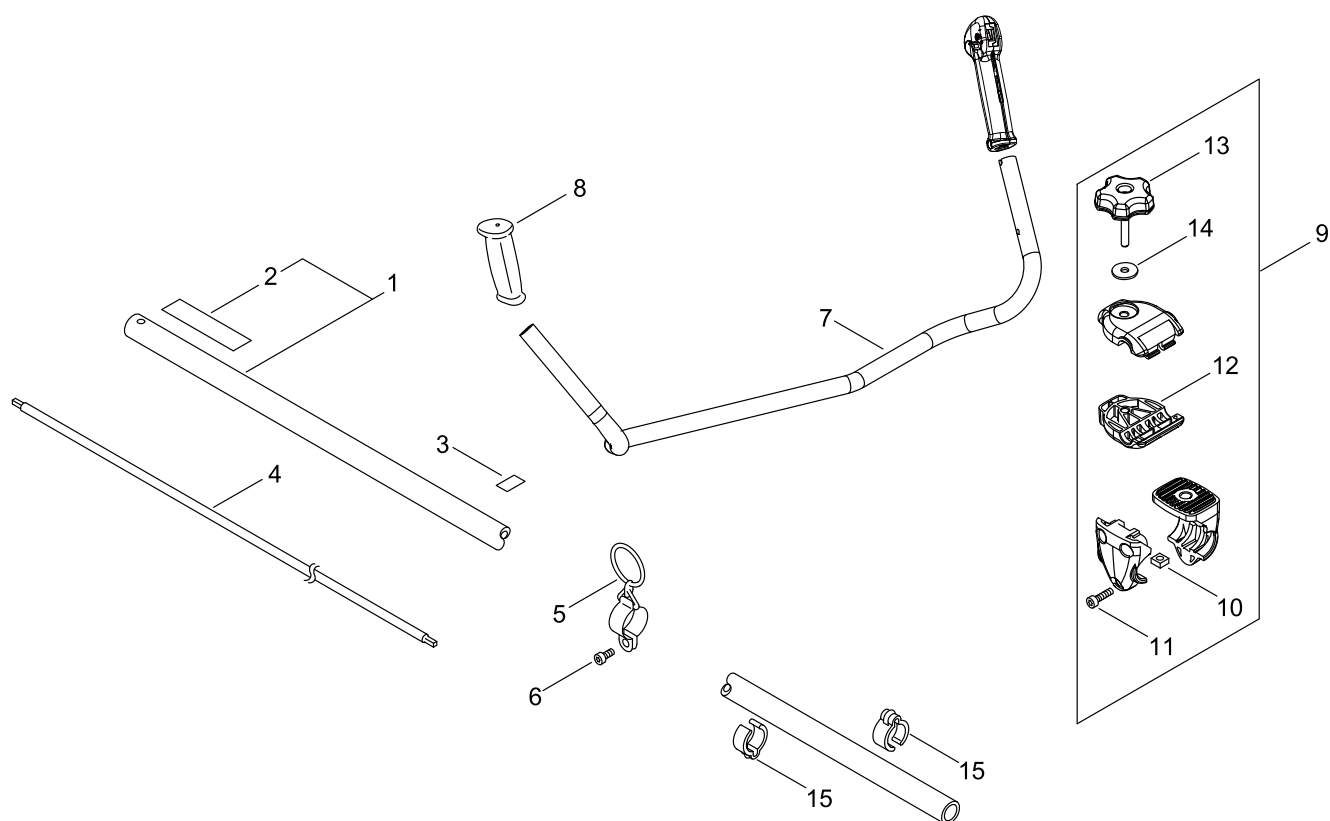

MAIN PIPE, HANDLE

KEY NO	LV(+)	Part No	Description	Qty	Standard	Comment
1		P021-049000	MAIN PIPE ASY	1		
2	+	890617-43130	LABEL,CAUTION	1		
3		890152-04930	LABEL, CAUTION	1		
4		C504-000050	SHAFT,DRIVE	1	7*1540	
5		C646-000060	RING, HARNESS	1	3-PIECE ASM	
6		V805-000140	BOLT, TORX 5	1	TB-5*12 10.9	
7		C400-000000	HANDLE,FRONT	1		
8		C403-000031	GRIP,HANDLE	1		
9		P021-016232	FIXTURE,ASY HANDLE	1		
10	+	900565-50008	NUT	1	8*1.25	
11	+	V805-000170	BOLT, TORX 5	3	TB-5*25 10.9	
12	+	C423-000043	FIXTURE,HANDLE	1		
13	+	V299-000110	KNOB,FASTENER	1		
14	+	605014-54230	WASHER	1		
15		224924-52130	CLIP	2	25MM	

THROTTLE

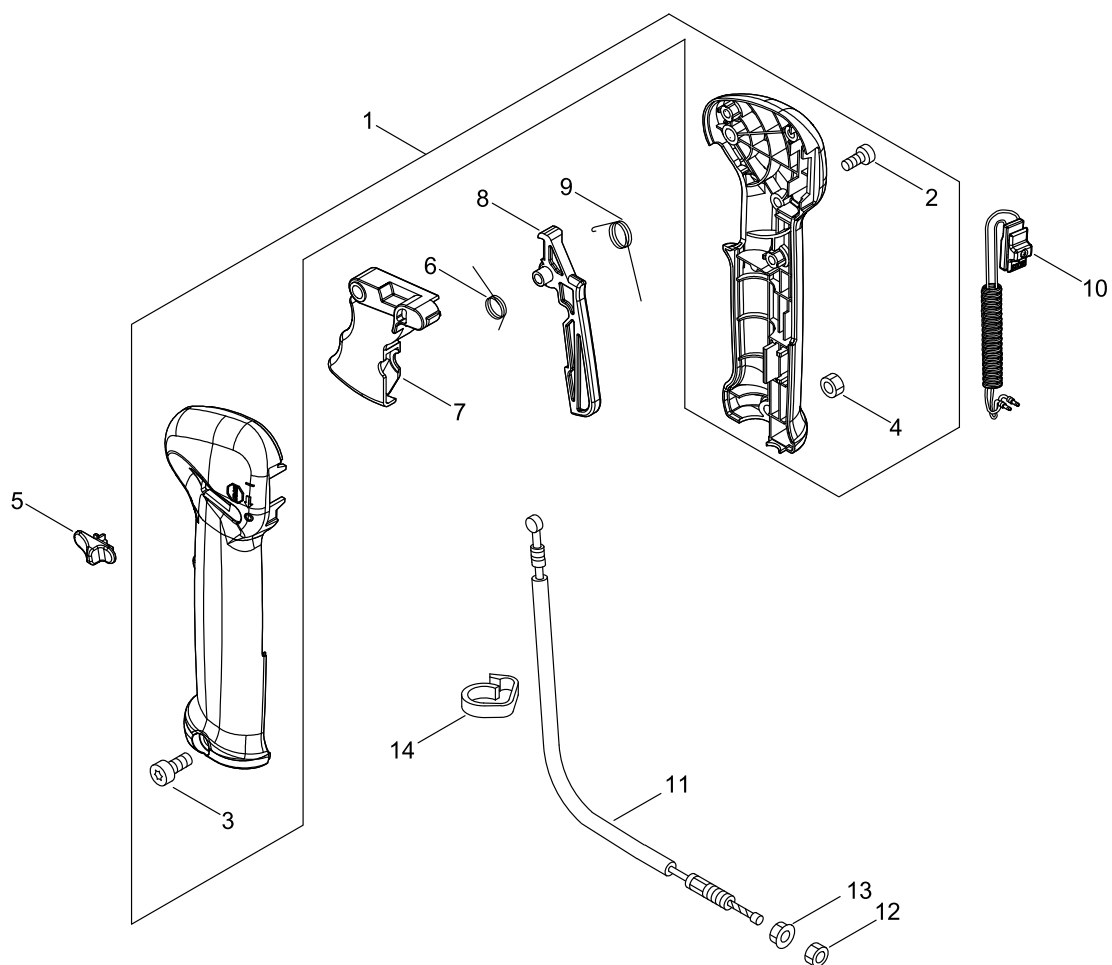

THROTTLE

KEY NO	LV(+)	Part No	Description	Qty	Standard	Comment
1		P021-016210	GRIP ASY,F-HANDLE	1		
2	+	V804-000010	BOLT, TORX 4	3	TT-4*16 DG 10.9	
3	+	V805-000050	BOLT, TORX 5	1	TB-5*30 10.9	
4	+	900500-00005	NUT 5	1	5	
5		C463-000020	KNOB, LATCH	1		
6		V452-000360	SPRING,TORSION	1		
7		C450-000270	CONTROL, THROTTLE	1		
8		C460-000111	LOCKOUT, THROTTLE	1	70MM	
9		V452-000350	SPRING,TORSION	1		
10		P021-051010	ON OFF SWITCH	1		
11		V430-004950	CABLE,BOWDEN	1		
12		900502-00006	NUT 6 (3N)	1	3N6	
13		900518-00006	NUT, FLANGE	1	6	
14		159112-09961	CLIP	1		

ACCESSORIES

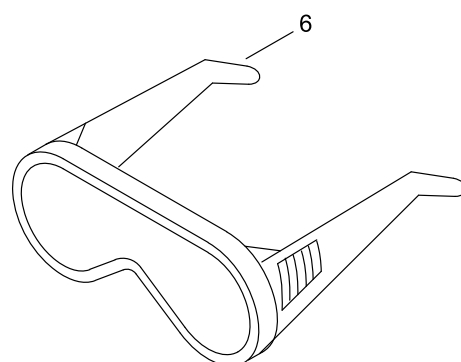
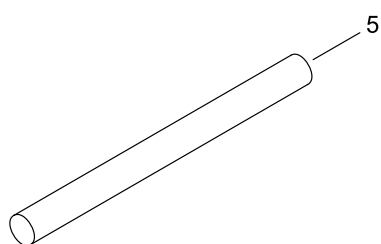
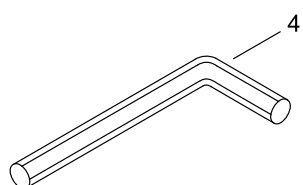
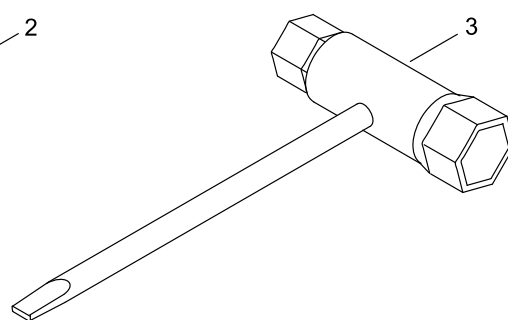
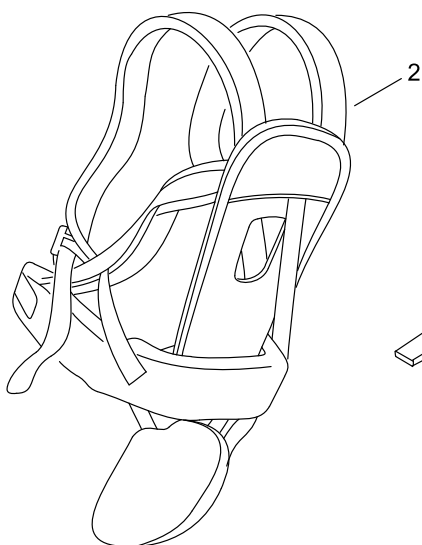
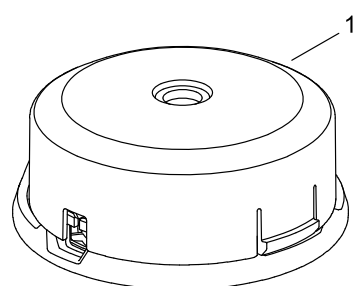

ACCESSORIES

KEY NO	LV(+)	Part No	Description	Qty	Standard	Comment
1		X047-000321	CUTTER,ASM LINE	1	Z-5 M10	
2		C062-000194	HARNESS,SHOULDER	1		
3		895415-66630	WRENCH, SPCKET	1		
4		X605-000170	TOOL,L WRENCH	1		
5		X606-000080	TOOL,BAR	1	5*120	
6		X690-000080	GOGGLE	1	SI CHINA, Z87.1	

NYLON LINE CUTTER

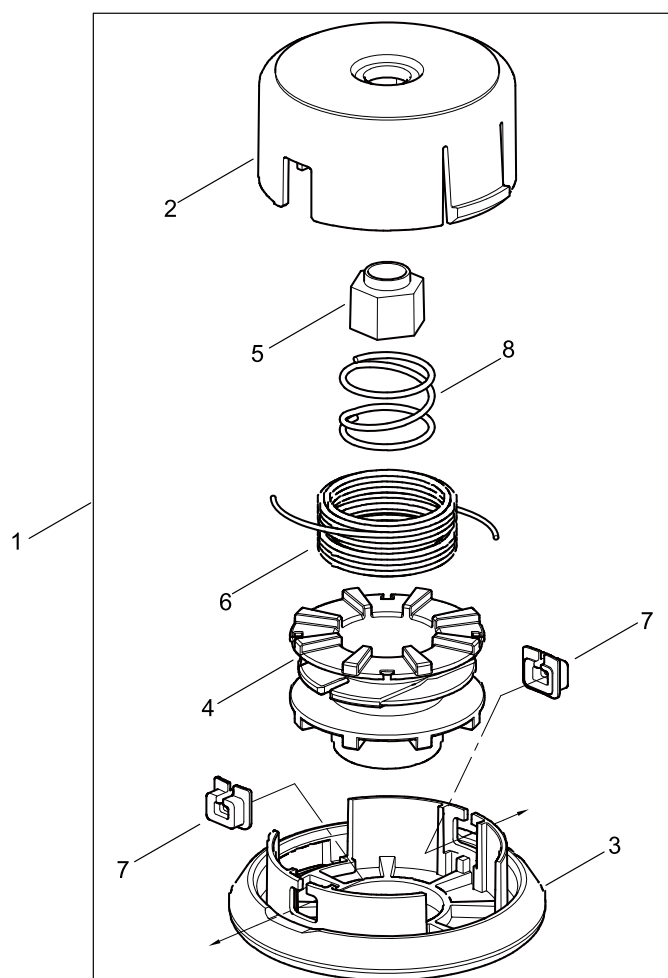

NYLON LINE CUTTER

KEY NO	LV(+)	Part No	Description	Qty	Standard	Comment
1		X047-000321	CUTTER,ASM LINE	1	Z-5 M10	
2	+	P022-010420	HOUSING	1		
3	+	P022-010410	COVER	1		
4	+	P022-010400	BOBBIN	1		
5	+	P022-023180	NUT	1		
6	+	P022-010380	NYLON CODE	1		
7	+	P022-000710	EYELET	2	T4	
8	+	P022-010370	SPRING	1		

NUMERICAL PARTS INDEX

Part No	Part description	Page	Part No	Part description	Page	Part No	Part description	Page
100013-3-5430	PIN, PISTON	2	177220-4-0630	SPRING, REWIND	18	900603-5-0008	WASHER	20
100014-5-3630	SPACER, PISTON PIN	2	177227-4-2030	GUIDE, ROPE	18	900701-0-0009	CIRCLIP 9	20
100015-0-3931	CIRCLIP, PISTON PIN	2	177228-2-7030	GRIP, STARTER	18	900701-0-0012	CIRCLIP 12	8
100142-1-2330	KEY, WOODRUFF	6	177236-6-1830	SCREW	18	900702-0-0022	CIRCLIP 22	20
100212-4-2031	OILSEAL	4	224924-5-2130	CLIP	22	900702-0-0028	CIRCLIP 28	8
123114-4-0630	SCREW	12	605014-5-4230	WASHER	22	900702-0-0042	CIRCLIP 42	8
123126-1-0631	SCREEN, INLET	12	610314-5-2130	PLATE, ADAPTER (L)	20	900702-0-0042	CIRCLIP 42	20
123137-1-9830	VALVE, INLET NEEDLE	12	610320-5-2130	NUT 10	20	900706-0-0010	CIRCLIP 10	20
123138-0-3930	PIN, METERING LEVER	12	610352-5-6830	PLATE, CUP	20	900706-0-0012	CIRCLIP 12	20
123140-2-7230	GASKET, M. DIAPHRAGM	12	610434-5-0031	BOLT 8* 8	20	900720-0-0012	O-RING 12	20
123142-0-3930	COVER, M. DIAPHRAGM	12	699229-5-6830	PLATE, COVER	20	900800-3-6001	BEARING, BALL 6001	4
123173-0-7930	CLIP	12	890152-0-4930	LABEL, CAUTION	22	900807-0-6001	BEARING, BALL 6001	8
123181-0-9560	PUMP, PRIMER	12	890332-5-2730	LABEL, CHOKE	10	900810-0-0629	BEARING, BALL 629	20
131016-5-5830	GASKET, FUEL CAP	14	890617-4-3130	LABEL, CAUTION	22	900810-3-6000	BEARING, BALL	4
131300-5-6431	VENT ASSEMBLY, FUEL	14	895415-6-6630	WRENCH, SPCKET	26	900812-0-6302	BEARING, BALL	20
132010-0-6530	PIPE 3*6* 85	14	900500-0-0005	NUT 5	24	900855-0-6900	BEARING, BALL 6900	20
132012-5-6030	PIPE	14	900502-0-0006	NUT 6 (3N)	24	900858-0-6900	BEARING, BALL 6900Z	20
132115-5-5930	GROMMET, FUEL	14	900515-0-0008	NUT, FLANGE 8	6	91316-04-010	SCREW	20
145862-4-0630	SCREEN, MUFFLER	16	900518-0-0006	NUT, FLANGE	24	A011-00-1460	CRANKSHAFT, ASY	2
156110-0-4920	BUSHING	6	900562-0-0005	NUT, LOCK	20	A021-00-4600	CARBURETOR, DIAPHRAGM	10
159112-0-9961	CLIP	24	900565-0-0005	NUT	18	A021-00-4600	CARBURETOR, DIAPHRAGM	12
175046-5-6030	SHAFT, CLUTCH	8	900565-0-0005	NUT	20	A051-00-3220	STARTER, RECOIL ASY	18
175048-0-5530	WASHER (I)	8	900565-5-0008	NUT	22	A052-00-0180	PULLEY, ASM STARTER	18
175049-5-6030	WASHER	8	900602-0-0005	WASHER 5	14	A101-00-0010	RING, PISTON	2

NUMERICAL PARTS INDEX

Part No	Part description	Page	Part No	Part description	Page	Part No	Part description	Page
A127-00-0470	COVER,DUST	18	A427-00-0220	CAP,SPARK PLUG	6	P003-00-4510	COVER, FUEL PUMP	12
A130-00-2330	CYLINDER	2	A553-00-0190	ARM, CLUTCH	8	P003-00-4530	GASKET, FUEL PUMP	12
A160-00-3280	COVER,CYLINDER	2	A556-00-1750	DRUM, CLUTCH	8	P003-00-4540	DIAPHRAGM, FUEL PUMP	12
A172-00-3140	COVER,FAN	8	A575-00-0690	FIXTURE, MAIN PIPE	8	P003-00-4560	SCREW	12
A175-00-0040	STAND	14	C062-00-0194	HARNESS, SHOULDER	26	P003-00-4570	SCREW	12
A202-00-0300	BELLOWS, INTAKE	10	C152-00-1030	CONNECTOR	6	P003-00-5300	BODY ASSEMBLY, PUMP	12
A206-00-0040	HOLDER, BELLOWS	10	C400-00-0000	HANDLE,FRONT	22	P003-00-5850	SWIVEL	12
A209-00-1000	PLATE, INSULATOR	10	C403-00-0031	GRIP,HANDLE	22	P003-00-5860	SCREW	12
A209-00-1010	PLATE, INSULATOR	10	C423-00-0043	FIXTURE,HANDLE	22	P003-00-5870	SPRING	12
A226-00-2030	ELEMENT, AIR FILTER	10	C450-00-0270	CONTROL, THROTTLE	24	P003-00-5880	NEEDLE	12
A226-00-2040	ELEMENT, AIR FILTER	10	C460-00-0111	LOCKOUT, THROTTLE	24	P003-00-5890	CLIP	12
A227-00-0050	PLATE, ELEMENT	10	C463-00-0020	KNOB, LATCH	24	P003-00-5900	PLATE	12
A232-00-1890	LID,CLEANER	10	C504-00-0050	SHAFT,DRIVE	22	P021-01-2210	CAP,FUEL ASY	14
A244-00-0320	PLATE, PREVENT	10	C534-00-0940	SHAFT, GEAR	20	P021-01-6210	GRIP ASY,F-HANDLE	24
A313-00-2060	GUIDE, EXHAUST	16	C535-00-0920	FIXTURE, BLADE	20	P021-01-6232	FIXTURE,ASY HANDLE	22
A320-00-1200	COVER,MUFFLER	16	C535-00-0930	FIXTURE, BLADE	20	P021-04-2900	SHIELD ASY, BLADE	20
A350-00-2350	TANK, FUEL	14	C550-00-0541	SHIELD, BLADE	20	P021-04-9000	MAIN PIPE ASY	22
A365-00-0060	CONNECTOR,CAP	14	C550-00-0560	SHIELD, BLADE	20	P021-05-0810	SHIELD BLADE ASY	20
A369-00-0470	STRAINER, FUEL	14	C552-00-0200	PLATE, SHIELD	20	P021-05-0840	PISTON KIT	2
A409-00-1320	ROTOR, MAGNETO	6	C554-00-0030	KNIFE, CORD	20	P021-05-0850	CRANKCASE KIT	4
A411-00-1710	COIL, IGNITION	6	C646-00-0060	RING, HARNESS	22	P021-05-0860	CLUTCH ASY	8
A413-00-0080	BOOT	8	P003-00-1630	LEVER, METERING	12	P021-05-0880	CLEANER CASE ASY	10
A425-00-0060	SPARKPLUG	6	P003-00-1670	DIAPHRAGM, METERING	12	P021-05-0900	MUFFLER ASY	16
A426-00-0010	TERMINAL, SPARKPLUG	6	P003-00-1710	WASHER	12	P021-05-1000	FAN COVER ASY	8

NUMERICAL PARTS INDEX

Part No	Part description	Page	Part No	Part description	Page	Part No	Part description	Page
P021-05-1010	ON OFF SWITCH	24	V104-00-2310	GASKET,EXHAUST	16	V805-00-0140	BOLT, TORX 5	18
P021-05-1190	GEAR CASE ASY	20	V186-00-0500	JOINT,PIPE	14	V805-00-0140	BOLT, TORX 5	22
P022-00-0710	EYELET	28	V299-00-0110	KNOB,FASTENER	22	V805-00-0150	BOLT, TORX 5	8
P022-00-2100	E-RING	18	V299-00-0290	KNOB,FASTENER	10	V805-00-0150	BOLT, TORX 5	10
P022-00-6510	SPRING, RETURN	18	V313-00-0090	WASHER,CIRCULAR 20	20	V805-00-0150	BOLT, TORX 5	20
P022-00-6850	PAWL, STARTER	18	V323-00-0070	WASHER,CIRCULAR 5	6	V805-00-0160	BOLT, TORX 5	8
P022-00-8270	SPRING,DAMPER	18	V430-00-4950	CABLE,BOWDEN	24	V805-00-0160	BOLT, TORX 5	14
P022-01-0370	SPRING	28	V451-00-1390	SPRING,TENSION	8	V805-00-0170	BOLT, TORX 5	8
P022-01-0380	NYLON CODE	28	V452-00-0350	SPRING,TORSION	24	V805-00-0170	BOLT, TORX 5	14
P022-01-0400	BOBBIN	28	V452-00-0360	SPRING,TORSION	24	V805-00-0170	BOLT, TORX 5	20
P022-01-0410	COVER	28	V452-00-1310	SPRING,TORSION	20	V805-00-0170	BOLT, TORX 5	22
P022-01-0420	HOUSING	28	V471-00-1230	PIPE	14	V805-00-0210	BOLT, TORX 5	2
P022-02-2110	ROPE, STARTER	18	V475-00-7540	TUBE	6	V805-00-0210	BOLT, TORX 5	6
P022-02-3180	NUT	28	V485-00-2880	LEAD	6	V805-00-0220	BOLT, TORX 5	4
P022-03-3310	PLATE, CAM	18	V490-00-1230	CLIP	14	V805-00-0250	BOLT, TORX 5	16
P022-03-3320	DRUM, STARTER	18	V490-00-1240	CLIP	14	V805-00-0260	BOLT, TORX 5	20
P022-03-7670	STOPPER, ROPE	18	V503-00-0040	SEAL,OIL 10	4	V805-00-0340	BOLT, TORX 5	10
P022-04-3670	STATER CASE	18	V554-00-0020	BEARING,NEEDLE 9	2	V806-00-0020	BOLT, TORX 6	20
V000-00-0110	GEAR SET, BEVEL	20	V804-00-0010	BOLT, TORX 4	24	V855-00-0000	BOLT, TORX 5	10
V100-00-0840	GASKET,CYL	2	V804-00-0030	BOLT, TORX 4	16	X047-00-0321	CUTTER,ASM LINE	26
V102-00-0300	GASKET, CRANKCASE	4	V805-00-0050	BOLT, TORX 5	24	X047-00-0321	CUTTER,ASM LINE	28
V103-00-1890	GASKET,INTAKE	10	V805-00-0130	BOLT, TORX 5	20	X524-00-1901	LABEL	10
V103-00-1900	GASKET,INTAKE	10	V805-00-0140	BOLT, TORX 5	2	X524-00-5230	LABEL	20
V104-00-2300	GASKET,EXHAUST	16	V805-00-0140	BOLT, TORX 5	16	X547-00-2980	LABEL,ECHO	18

NUMERICAL PARTS INDEX

Part No	Part description	Page
X547-00-2990	LABEL,ECHO	2
X605-00-0170	TOOL,L WRENCH	26
X606-00-0080	TOOL,BAR	26
X690-00-0080	GOGGLE	26