

# M262S

Published:07/26/2018

## TABLE OF CONTENTS

---

CYLINDER, PISTON, CRANKSHAFT.....	1
CRANKCASE .....	3
MAGNETO.....	5
CLUTCH.....	7
AIR CLEANER, CARBURETOR.....	9
CARBURETOR.....	11
FUEL TANK.....	13
MUFFLER .....	15
RECOIL STARTER, PULLY .....	17
MAIN PIPE, HANDLE.....	19
THROTTLE .....	21
ACCESSORIES .....	23

# CYLINDER, PISTON, CRANKSHAFT

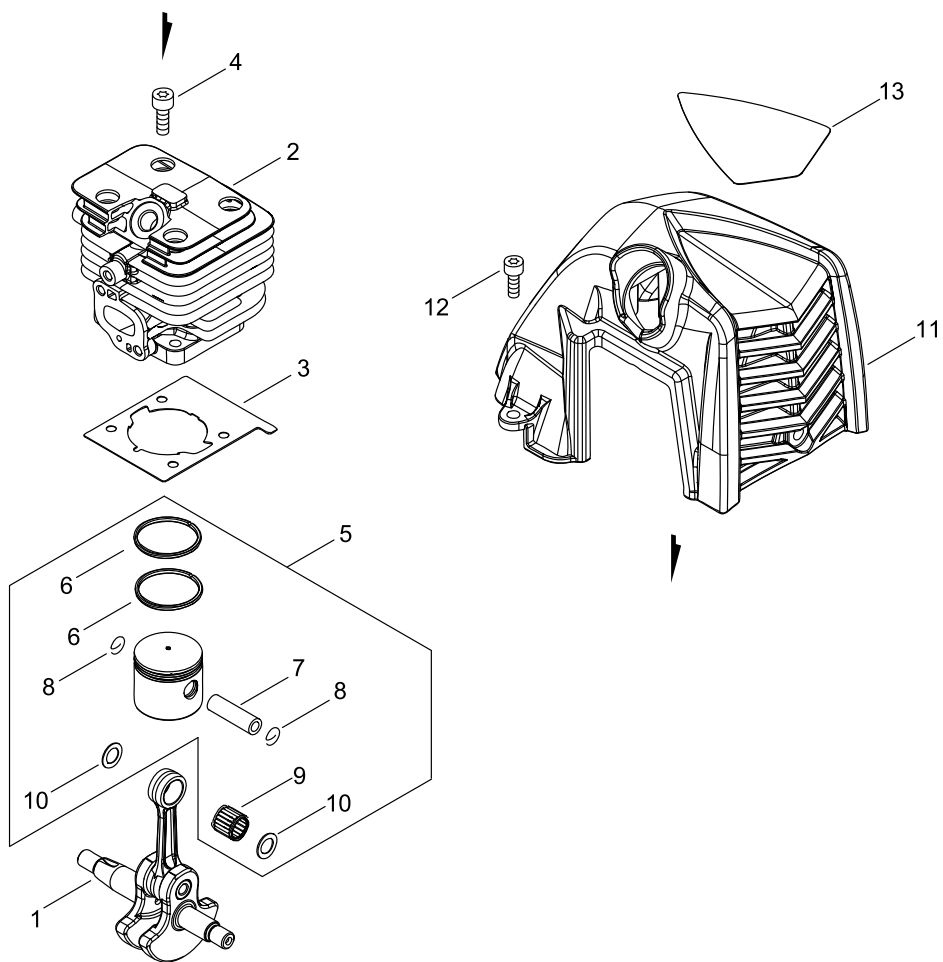

## CYLINDER, PISTON, CRANKSHAFT

KEY NO	LV(+)	Part No	Description	Qty	Standard	Comment
1		A011-001460	CRANKSHAFT,ASY	1		
2		A130-002330	CYLINDER	1		
3		V100-000840	GASKET,CYL	1		
4		V805-000210	BOLT, TORX 5	4	TB-5*20 12.9	
5		P021-050840	PISTON KIT	1		
6	+	A101-000010	RING,PISTON	2		
7	+	100013-35430	PIN, PISTON	1	6*9*27.8	
8	+	100015-03931	CIRCLIP, PISTON PIN	2		
9	+	V554-000020	BEARING,NEEDLE 9	1	KTV-91212EG14-B2	
10	+	100014-53630	SPACER, PISTON PIN	2		
11		A160-003290	COVER,CYLINDER	1		
12		V835-000010	BOLT, TORX 5	2	TB-5*12 10.9	
13		X562-001100	LABEL,SHINDAIWA	1	SHINDAIWA+ M262S	

# CRANKCASE

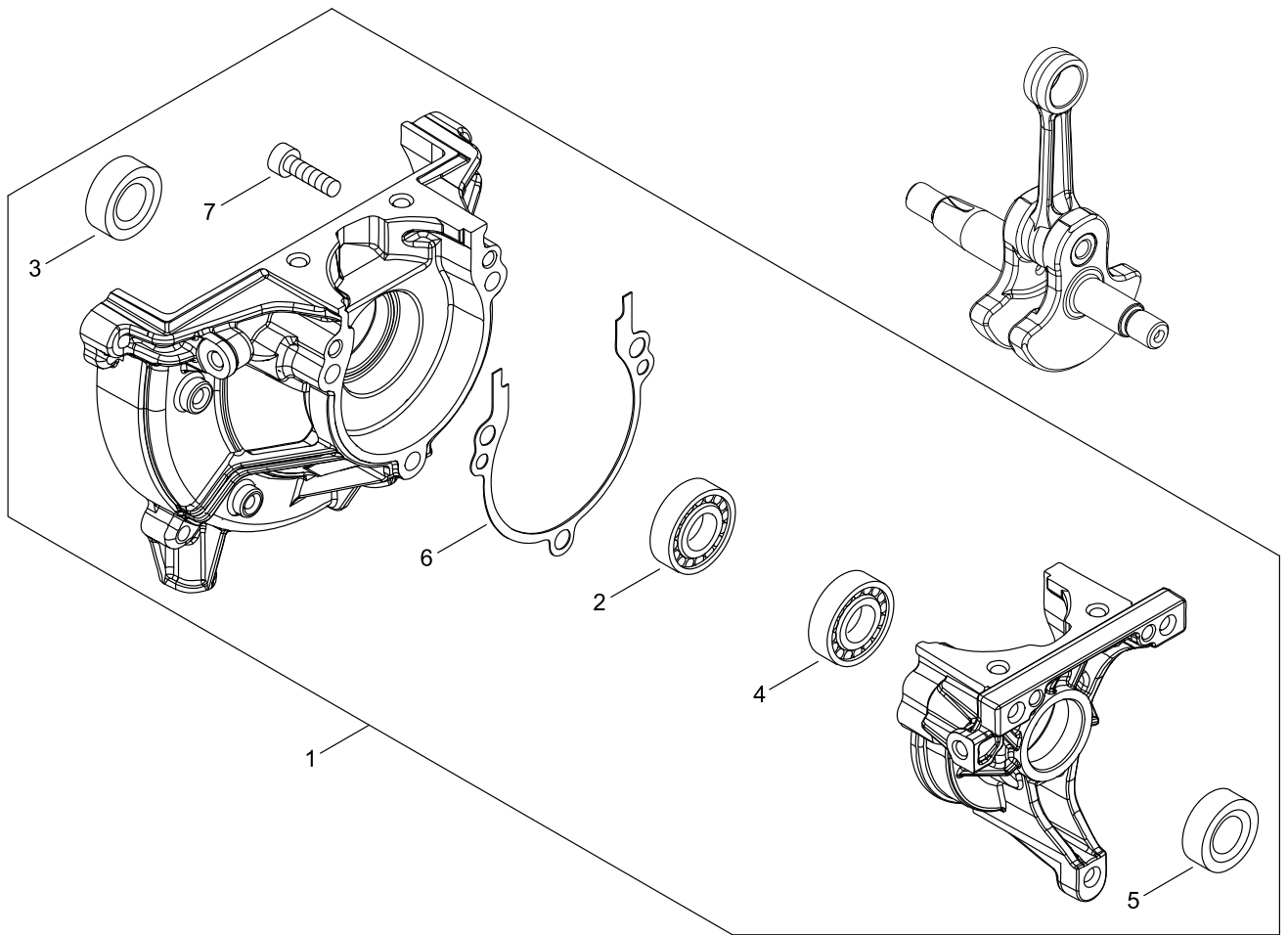

## CRANKCASE

KEY NO	LV(+)	Part No	Description	Qty	Standard	Comment
1		P021-050850	CRANKCASE KIT	1		
2	+	900800-36001	BEARING, BALL 6001	1	6001/C3	
3	+	100212-42031	OILSEAL	1	ISCD 12*22*4.5	
4	+	900810-36000	BEARING, BALL	1	6000	
5	+	V503-000040	SEAL,OIL 10	1	ISCD 10*20*5F	
6	+	V102-000300	GASKET,CRANKCASE	1		
7	+	V805-000220	BOLT, TORX 5	3	TB-5*25 12.9	

# MAGNETO

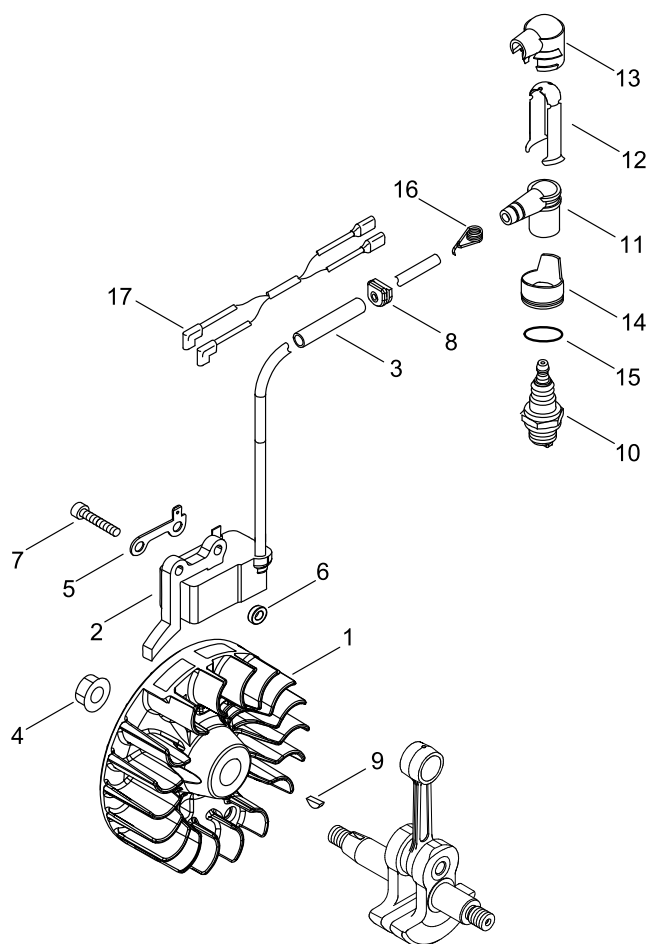

## MAGNETO

KEY NO	LV(+)	Part No	Description	Qty	Standard	Comment
1		A409-001320	ROTOR, MAGNETO	1		
2		A411-001790	COIL, IGNITION	1	ID#A10073A	
3		V475-007540	TUBE	1		
4		900515-00008	NUT, FLANGE 8	1	8	
5		C152-001030	CONNECTOR	1		
6		V323-000070	WASHER,CIRCULAR 5	2	5.2*10*3	
7		V805-000210	BOLT, TORX 5	2	TB-5*20 12.9	
8		156110-04920	BUSHING	1		
9		100142-12330	KEY, WOODRUFF	1		
10		A425-000060	SPARKPLUG	1	CMR7H	
11		A427-000090	PLUG CAP	1		
12		V151-000170	PLATE,CUP	1		
13		A429-000110	PLUG CAP COVER	1		
14		J473-000120	PIECE,COVER	1		
15		900720-00022	O-RING 22	1	P-22	
16		A426-000010	TERMINAL,SPARKPLUG	1		
17		V485-002880	LEAD	1		



## CLUTCH

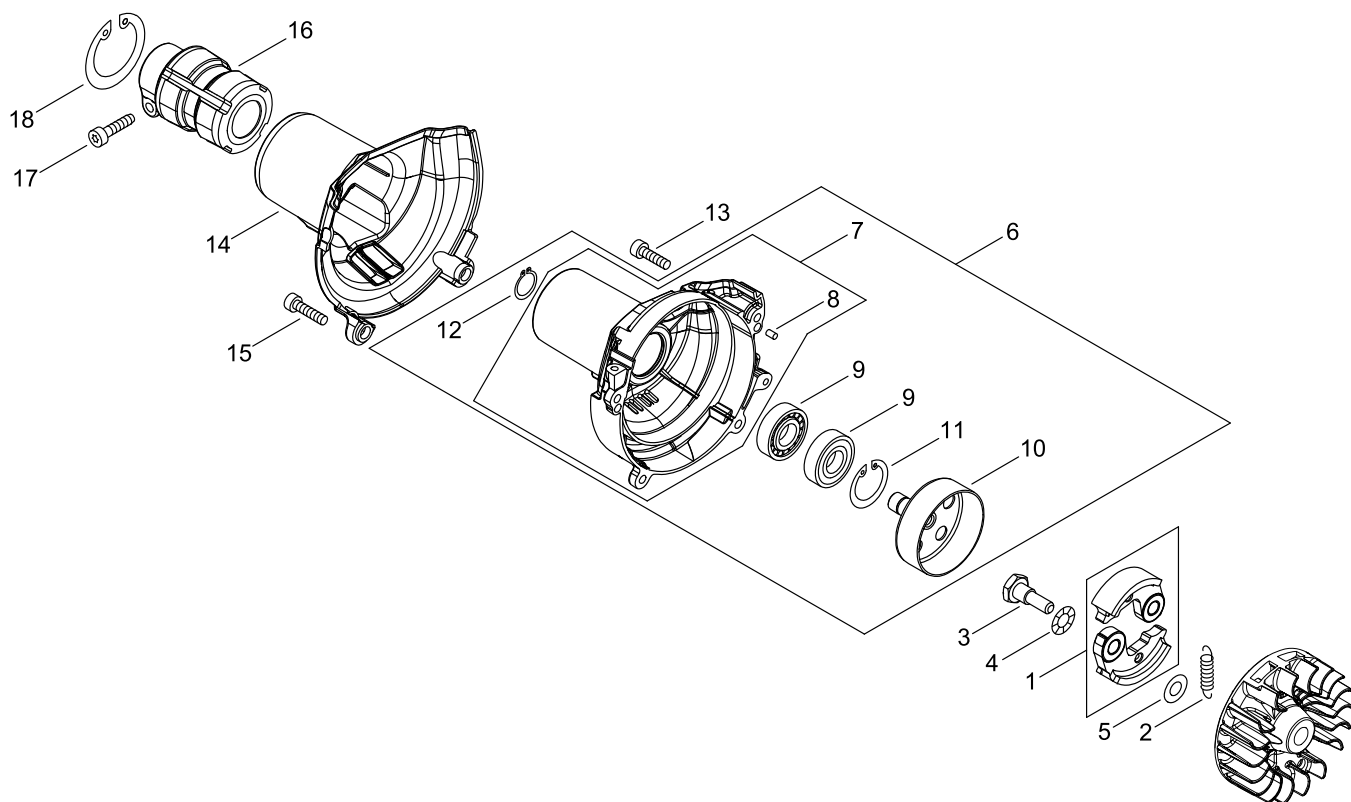

## CLUTCH

KEY NO	LV(+)	Part No	Description	Qty	Standard	Comment
1		P100-002270	ARM,CLUTCH SET	1		
2		V451-001390	SPRING,TENSION	1	172N/34MM	
3		175046-56030	SHAFT, CLUTCH	2		
4		175049-56030	WASHER	2	8.5*16*0.5	
5		175048-05530	WASHER (I)	2	6.2*19*1.0	
6		P100-005340	FAN COVER ASY	1		
7	+	A172-003142	COVER,FAN	1		
8	++	900330-40080	PIN F 4*8	2	4*8	
9	+	900807-06001	BEARING, BALL 6001	2	6001V(LB)	
10	+	A556-001760	DRUM,CLUTCH	1		
11	+	900702-00028	CIRCLIP 28	1	CR-28	
12	+	900701-00012	CIRCLIP 12	1	CS-12	
13		V805-000150	BOLT, TORX 5	2	TB-5*16 10.9	
14		A413-000090	BOOT	1		
15		V805-000160	BOLT, TORX 5	2	TB-5*20 10.9	
16		A575-000640	FIXTURE, MAIN PIPE	1		
17		V805-000170	BOLT, TORX 5	1	TB-5*25 10.9	
18		900702-00042	CIRCLIP 42	1	CR-42	

# AIR CLEANER, CARBURETOR

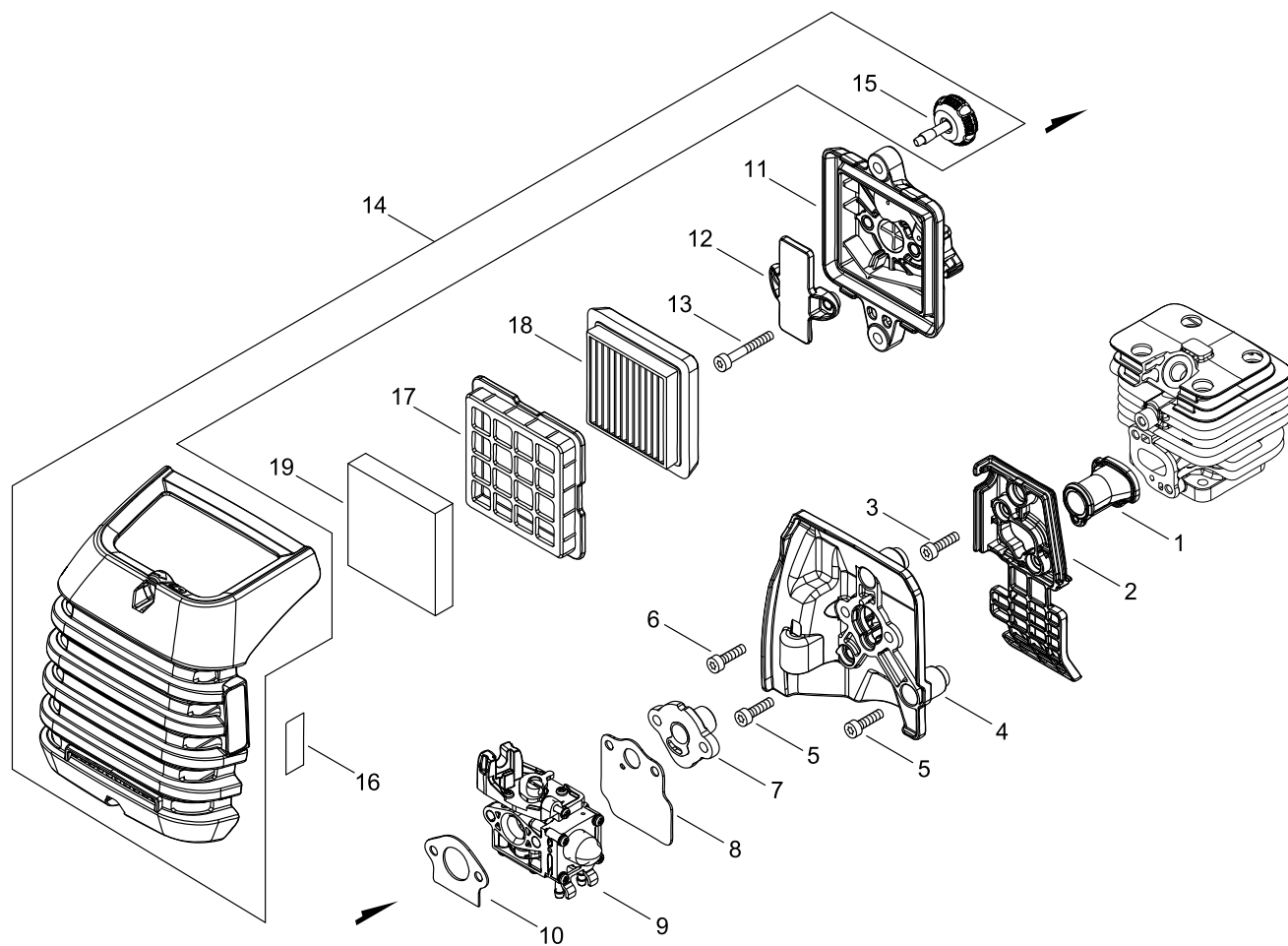

## AIR CLEANER, CARBURETOR

KEY NO	LV(+)	Part No	Description	Qty	Standard	Comment
1		A202-000300	BELLOWS, INTAKE	1		
2		A206-000040	HOLDER, BELLOWS	1		
3		V253-001020	SCREW,5	2	TB2411 10MM	
4		A209-001010	PLATE, INSULATOR	1		
5		V805-000150	BOLT, TORX 5	2	TB-5*16 10.9	
6		V855-000000	BOLT, TORX 5	1	TB-5*20	
7		A209-001000	PLATE, INSULATOR	1		
8		V103-001890	GASKET,INTAKE	1		
9		A021-004600	CARBURETOR, DIAPHRAGM	1	WYG-9	
10		V103-001900	GASKET,INTAKE	1		
11		P021-050880	CLEANER CASE ASY	1		
12		A244-000320	PLATE, PREVENT	1		
13		V805-000340	BOLT, TORX 5	2	TB-5*60 10.9	
14		P100-003600	LID,CLEANER ASY	1		
15	+	V299-000640	KNOB,FASTENER	2		
16		X506-000170	LABEL,CHOKE	1	SYMBOLS + T	
17		A227-000050	PLATE, ELEMENT	1		
18		A226-002030	ELEMENT, AIR FILTER	1		
19		A226-002040	ELEMENT, AIR FILTER	1	HP-70	

# CARBURETOR

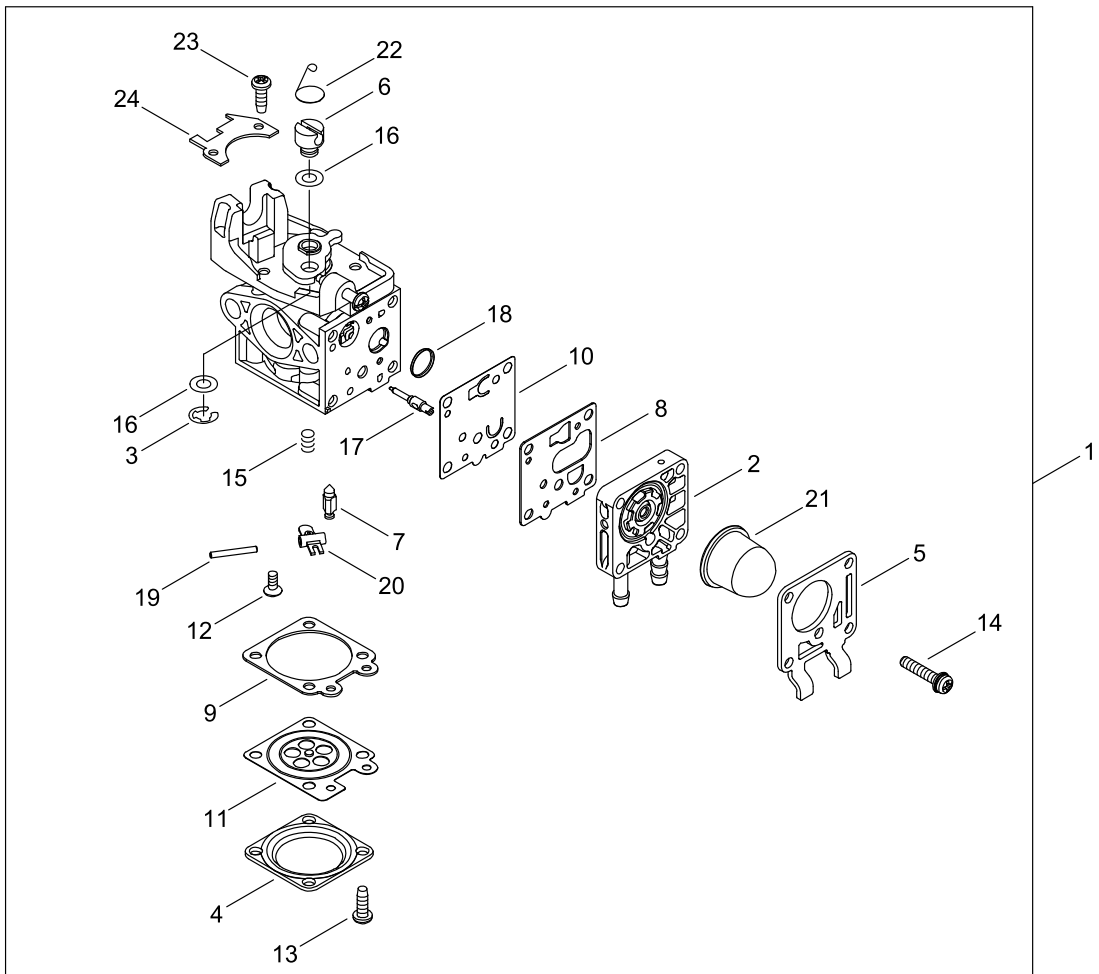

## CARBURETOR

KEY NO	LV(+)	Part No	Description	Qty	Standard	Comment
1		A021-004600	CARBURETOR, DIAPHRAGM	1	WYG-9	
2	+	P003-005300	BODY ASSEMBLY, PUMP	1		
3	+	123173-07930	CLIP	1		
4	+	123142-03930	COVER, M. DIAPHRAGM	1		
5	+	P003-004510	COVER, FUEL PUMP	1		
6	+	P003-005850	SWIVEL	1		
7	+	123137-19830	VALVE, INLET NEEDLE	1		
8	+	P003-004530	GASKET, FUEL PUMP	1		
9	+	123140-27230	GASKET,M. DIAPHRAGM	1		
10	+	P003-004540	DIAPHRAGM, FUEL PUMP	1		
11	+	P003-001670	DIAPHRAGM, METERING	1		
12	+	P003-005860	SCREW	1		
13	+	P003-004560	SCREW	4		
14	+	P003-004570	SCREW	4		
15	+	P003-005870	SPRING	1		
16	+	P003-001710	WASHER	2		
17	+	P003-005880	NEEDLE	1		
18	+	123126-10631	SCREEN, INLET	1		
19	+	123138-03930	PIN, METERING LEVER	1		
20	+	P003-001630	LEVER, METERING	1		
21	+	123181-09560	PUMP, PRIMER	1		
22	+	P003-005890	CLIP	1		
23	+	123114-40630	SCREW	3		
24	+	P003-005900	PLATE	1		

# FUEL TANK

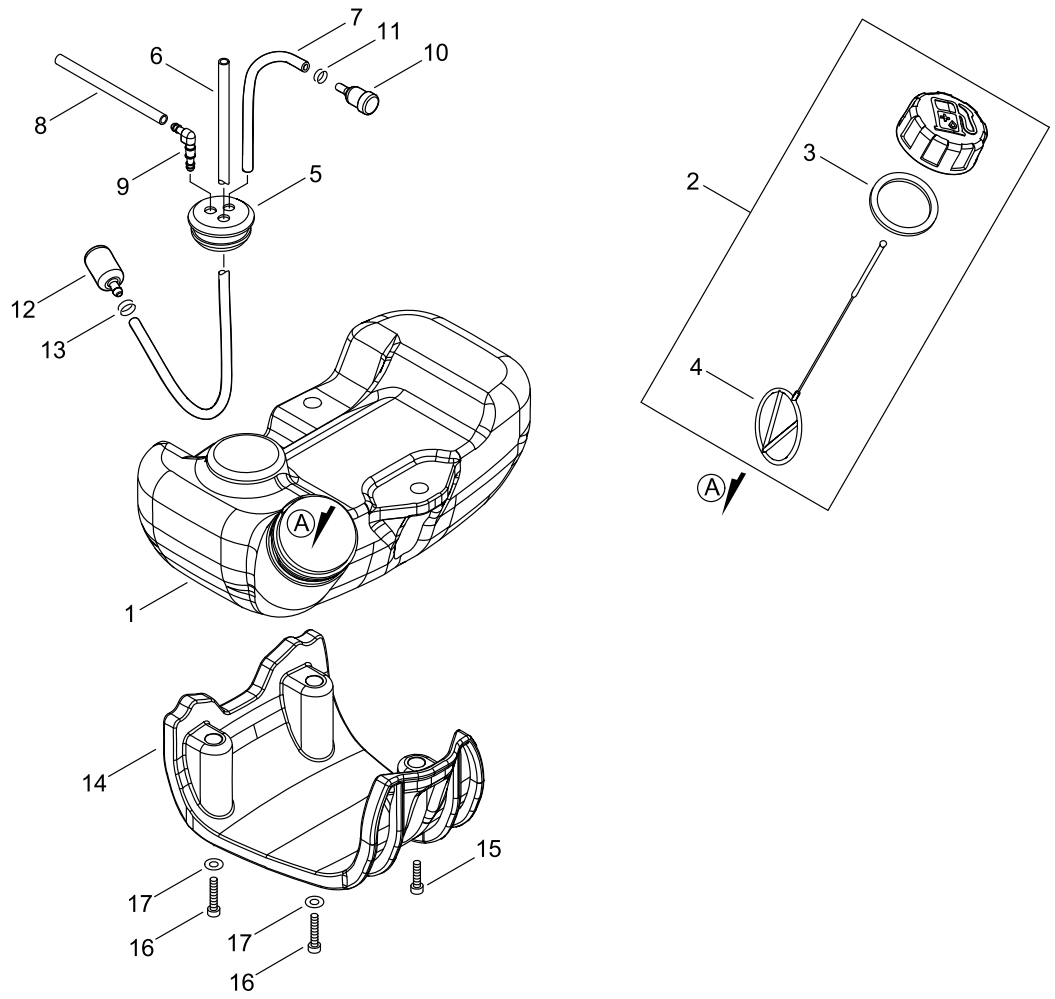

## FUEL TANK

KEY NO	LV(+)	Part No	Description	Qty	Standard	Comment
1		A350-002350	TANK, FUEL	1		
2		P021-035680	FUEL CAP ASY	1	T242	
3	+	131016-55830	GASKET, FUEL CAP	1		
4	+	A365-000060	CONNECTOR,CAP	1	L=123	
5		132115-55930	GROMMET, FUEL	1		
6		V471-001230	PIPE	1	3*5*210 NBR	
7		132010-06530	PIPE 3*6* 85	1	3*6* 85	
8		132012-56030	PIPE	1	3*6*80 YL	
9		V186-000500	JOINT,PIPE	1		
10		A356-000031	VALVE,CHECK	1		
11		V490-001230	CLIP	1		
12		A369-000470	STRAINER, FUEL	1		
13		V490-001240	CLIP	1		
14		A175-000040	STAND	1		
15		V805-000160	BOLT, TORX 5	1	TB-5*20 10.9	
16		V805-000170	BOLT, TORX 5	2	TB-5*25 10.9	
17		900602-00005	WASHER 5	2	5.3*10*1	



## MUFFLER

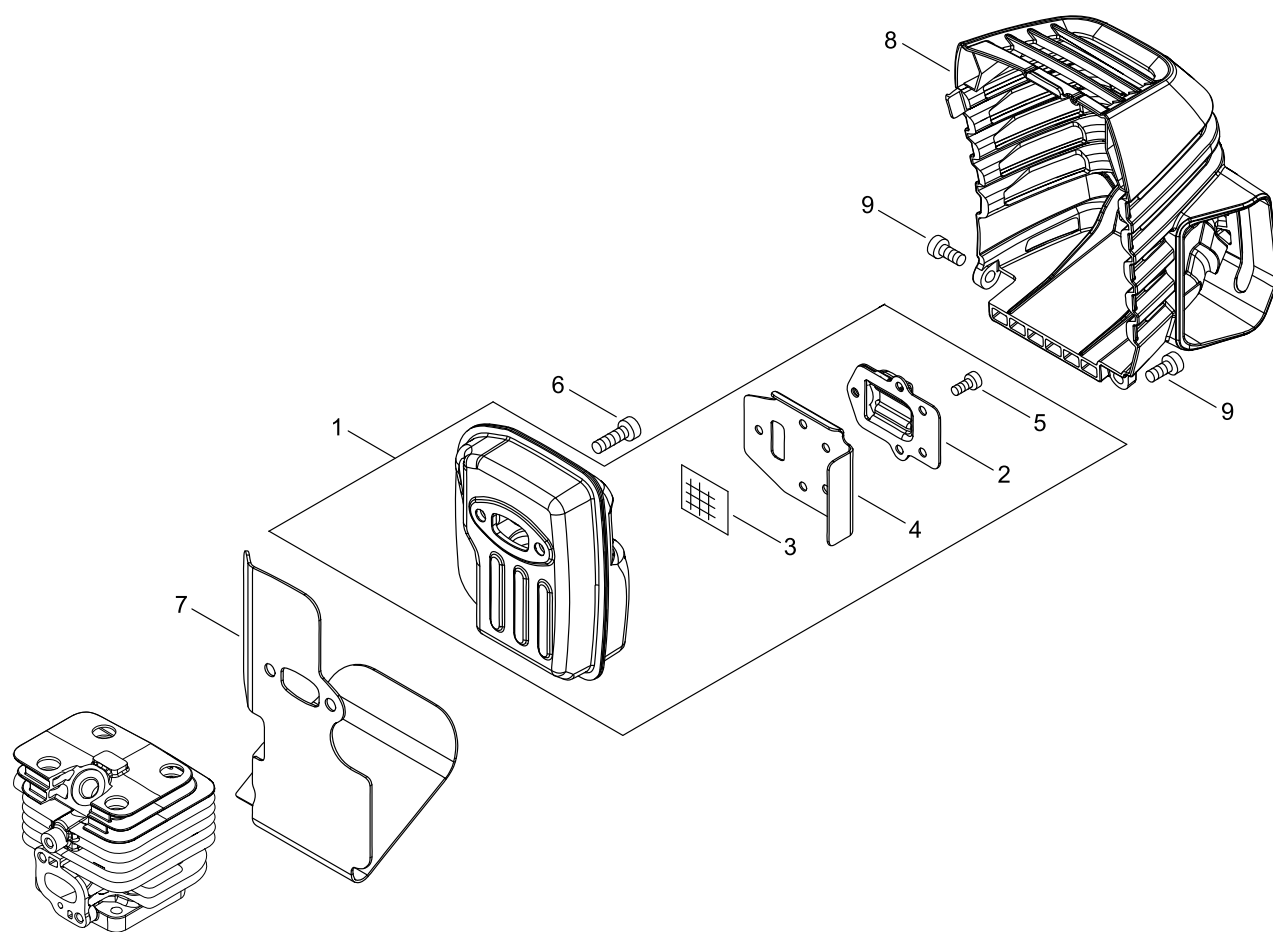

## MUFFLER

KEY NO	LV(+)	Part No	Description	Qty	Standard	Comment
1		P100-004020	MUFFLER ASY	1		
2	+	A313-002060	GUIDE, EXHAUST	1		
3	+	145862-40630	SCREEN, MUFFLER	1		
4	+	V104-002300	GASKET,EXHAUST	1		
5	+	V804-000030	BOLT, TORX 4	5	TB-4*8 10.9	
6		V805-000250	BOLT, TORX 5	2	TB-5*16 12.9	
7		V104-002310	GASKET,EXHAUST	1		
8		A320-001200	COVER,MUFFLER	1		
9		V835-000010	BOLT, TORX 5	2	TB-5*12 10.9	

# RECOIL STARTER, PULLY

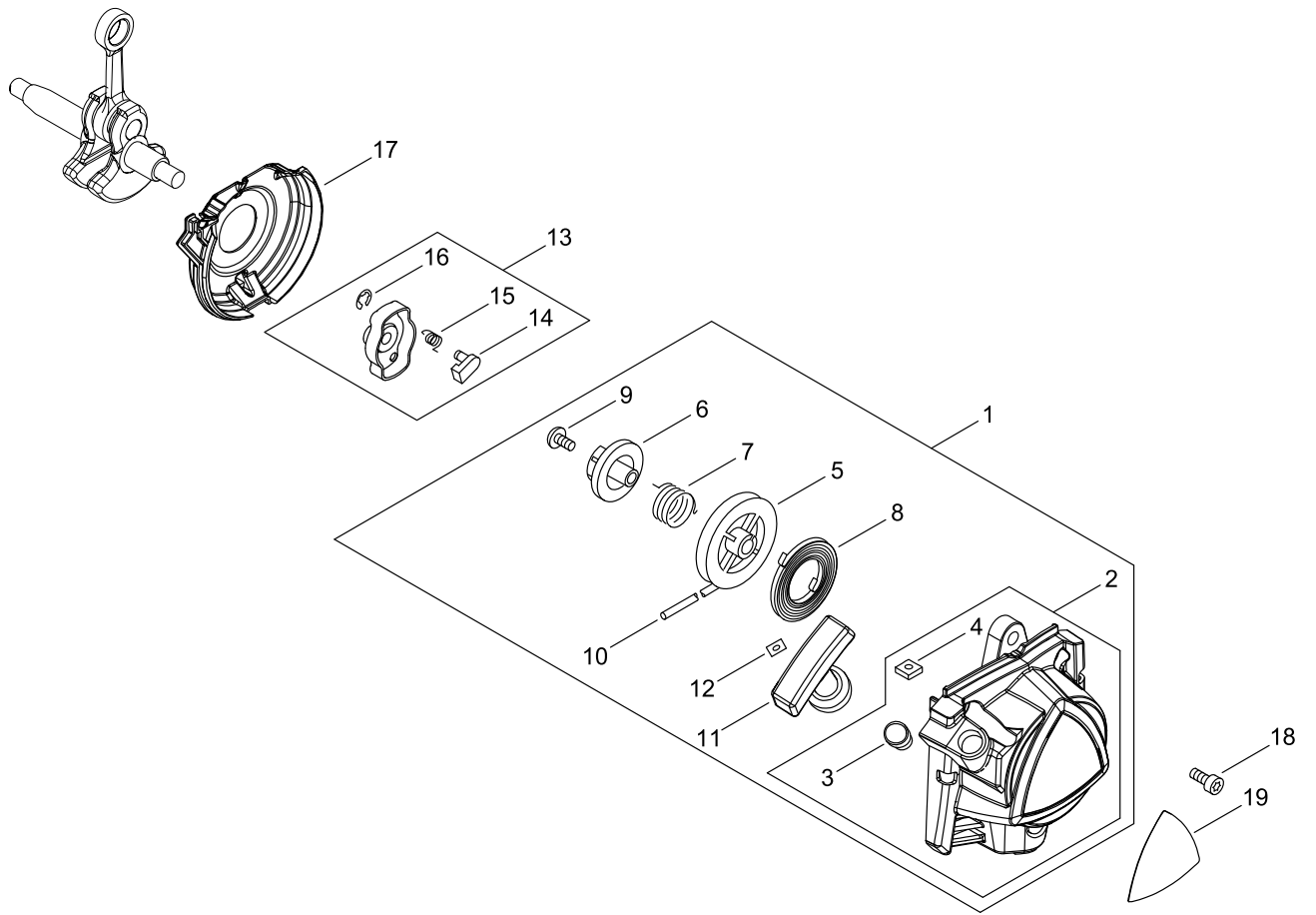

## RECOIL STARTER, PULLY

KEY NO	LV(+)	Part No	Description	Qty	Standard	Comment
1		A051-003220	STARTER,RECOIL ASY	1		
2	+	P022-043670	STATER CASE	1		
3	++	P022-045770	GUIDE, ROPE	1		
4	++	900565-00005	NUT	2	5	
5	+	P022-033320	DRUM, STARTER	1		
6	+	P022-033310	PLATE, CAM	1		
7	+	P022-008270	SPRING,DAMPER	1		
8	+	177220-40630	SPRING, REWIND	1		
9	+	177236-61830	SCREW	1		
10	+	P022-022110	ROPE, STARTER	1		
11	+	177228-27030	GRIP, STARTER	1		
12	+	P022-037670	STOPPER, ROPE	1		
13		A052-000180	PULLEY,ASM STARTER	1		
14	+	P022-006850	PAWL, STARTER	2		
15	+	177234-12220	SPRING, PAWL	2		
16	+	P022-002100	E-RING	2	4	
17		A127-000470	COVER,DUST	1		
18		V805-000140	BOLT, TORX 5	3	TB-5*12 10.9	
19		X562-001090	LABEL,SHINDAIWA	1	SHINDAIWA+ M262S	

# MAIN PIPE, HANDLE

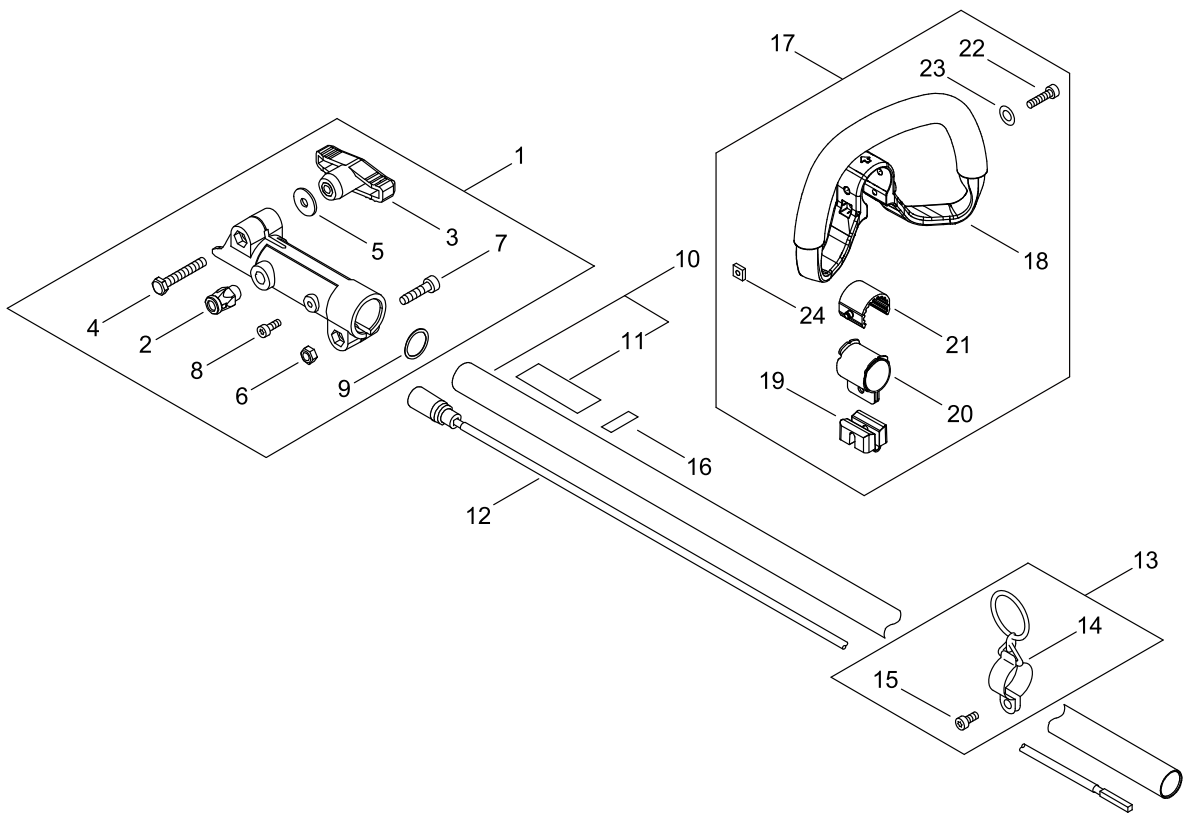

## MAIN PIPE, HANDLE

KEY NO	LV(+)	Part No	Description	Qty	Standard	Comment
1		C510-000330	COUPLING, MAIN PIPE	1	FINAL COUPLING	
2	+	P100-005150	LATCH ASY	1		
3	+	V299-000660	KNOB,FASTENER	1	M6X1 WING ASS'Y	
4	+	91085-06040	BOLT	1	6*40	
5	+	V304-000040	WASHER,CIRCULAR 6	1	6.6*20*1.6	
6	+	900514-00006	NUT 6	1	6	
7	+	V806-000020	BOLT, TORX 6	1	TB-6*25 10.9	
8	+	V805-000130	BOLT, TORX 5	1	TB-5*10 10.9	
9	+	V312-000010	WASHER,CIRCULAR 18	1	18*21.85*.203	
10		P100-005860	MAIN PIPE ASY	1		
11	+	X505-006800	LABEL,CAUTION	1	ISO 3-SYMBOL	
12		C506-000550	SHAFT, FLEXIBLE	1	L:31.58" / 802MM	
13		P021-051240	HOOK ASY	1		
14	+	C646-000060	RING, HARNESS	1	3-PIECE ASM	
15	+	V805-000140	BOLT, TORX 5	1	TB-5*12 10.9	
16		890152-04930	LABEL, CAUTION	1		
17		P021-048780	HANDLE ASY	1		
18	+	C400-001020	HANDLE,FRONT	1		
19	+	C401-000280	PIECE,HANDLE	1		
20	+	C610-000050	FIXTURE, CUSHION	1		
21	+	V420-003700	CUSHION	1		
22	+	V805-000070	BOLT, TORX 5	1	TB-5*40 10.9	
23	+	900603-00005	WASHER 5	1	5.5*12*0.8	
24	+	V263-000130	NUT	1		

# THROTTLE

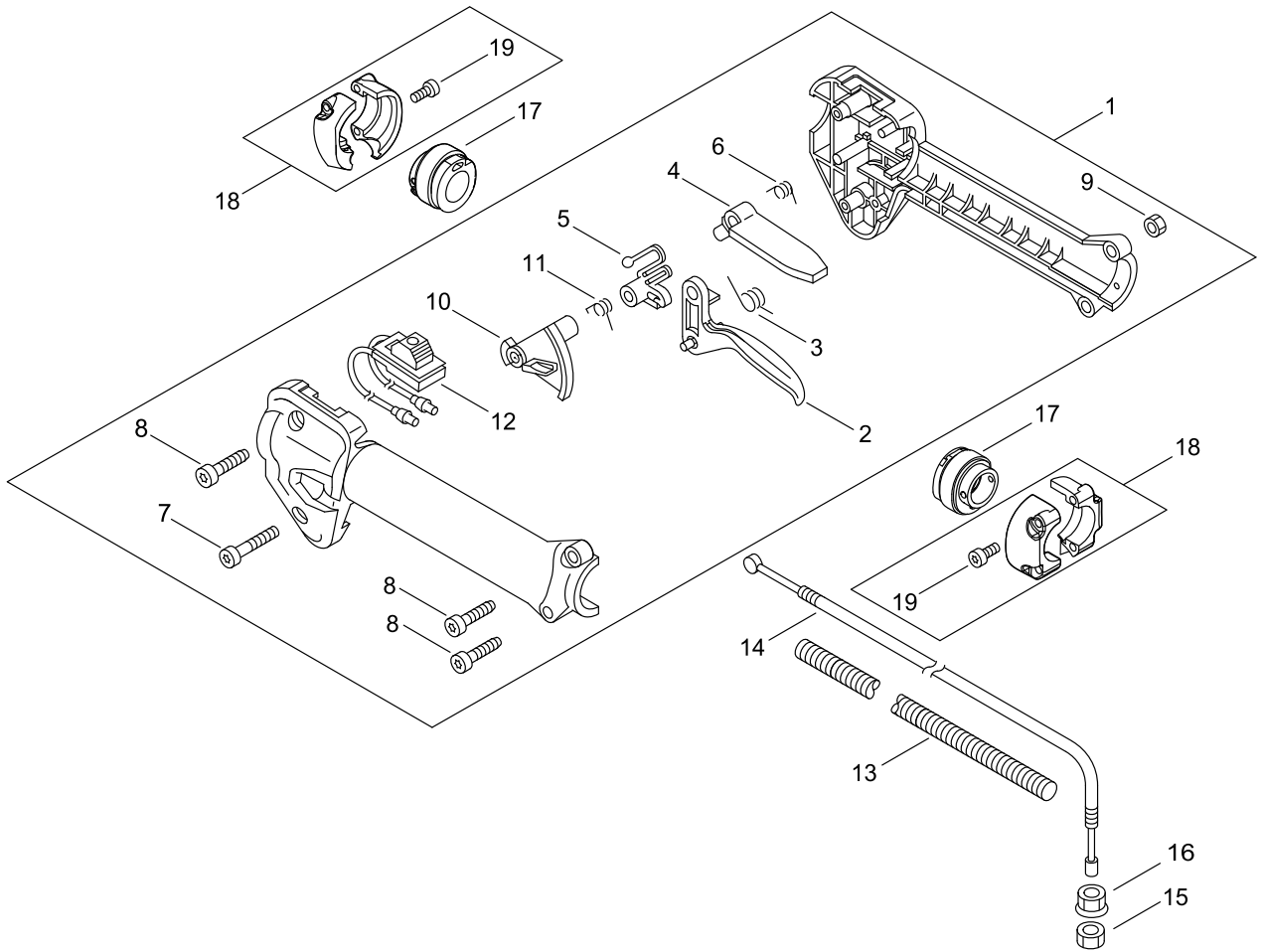

## THROTTLE

KEY NO	LV(+)	Part No	Description	Qty	Standard	Comment
1		P100-005890	THROTTLE ASY	1		
2	+	C450-000780	TRIGGER,THROTTLE	1		
3	+	178043-42230	SPRING, THR. RETURN	1		
4	+	C460-000370	LOCKOUT,THROTTLE	1		
5	+	C461-000000	LATCH,THROTTLE	1		
6	+	178013-52630	SPRING, THR. LOCK	1		
7	+	V805-000060	BOLT, TORX 5	1	TB-5*35 10.9	
8	+	V805-000170	BOLT, TORX 5	3	TB-5*25 10.9	
9	+	900500-00005	NUT 5	4	5	
10	+	C461-000110	LATCH,THROTTLE	1		
11	+	V452-000120	SPRING,TORSION	1		
12	+	A440-002800	SWITCH, ON OFF	1		
13		V475-008930	TUBE	1		
14		V430-004940	CABLE,BOWDEN	1		
15		900502-00006	NUT 6 (3N)	1	3N6	
16		900518-00006	NUT, FLANGE	1	6	
17		V420-000960	CUSHION	2		
18		P021-050990	HANDLE FIXTURE ASY	1		
19	+	V805-000170	BOLT, TORX 5	4	TB-5*25 10.9	



## ACCESSORIES

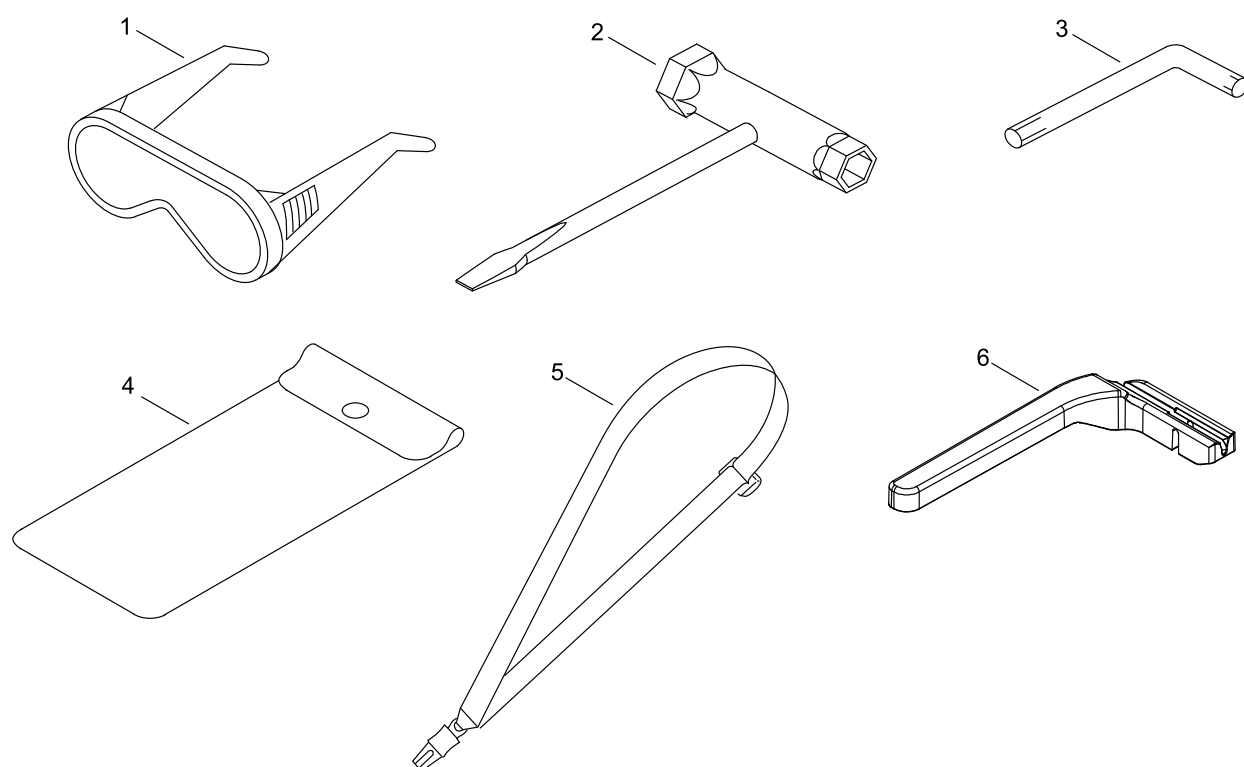

## ACCESSORIES

KEY NO	LV(+)	Part No	Description	Qty	Standard	Comment
1		X690-000080	GOGGLE	1	SI CHINA, Z87.1	
2		895415-66630	WRENCH, SPCKET	1		
3		X605-000170	TOOL,L WRENCH	1		
4		898510-07130	BAG, TOOL	1		
5		C062-000700	HARNESS, SHOULDER	1	SINGLE SLING	
6		C405-000420	BARRIER	1		

# NUMERICAL PARTS INDEX

Part No	Part description	Page	Part No	Part description	Page	Part No	Part description	Page
100013-3-5430	PIN, PISTON	2	177234-1-2220	SPRING, PAWL	18	A011-00-1460	CRANKSHAFT,ASY	2
100014-5-3630	SPACER, PISTON PIN	2	177236-6-1830	SCREW	18	A021-00-4600	CARBURETOR, DIAPHRAGM	10
100015-0-3931	CIRCLIP, PISTON PIN	2	178013-5-2630	SPRING, THR. LOCK	22	A021-00-4600	CARBURETOR, DIAPHRAGM	12
100142-1-2330	KEY, WOODRUFF	6	178043-4-2230	SPRING, THR. RETURN	22	A051-00-3220	STARTER,RECOIL ASY	18
100212-4-2031	OILSEAL	4	890152-0-4930	LABEL, CAUTION	20	A052-00-0180	PULLEY,ASM STARTER	18
123114-4-0630	SCREW	12	895415-6-6630	WRENCH, SPCKET	24	A101-00-0010	RING,PISTON	2
123126-1-0631	SCREEN, INLET	12	898510-0-7130	BAG, TOOL	24	A127-00-0470	COVER,DUST	18
123137-1-9830	VALVE, INLET NEEDLE	12	900330-4-0080	PIN F 4*8	8	A130-00-2330	CYLINDER	2
123138-0-3930	PIN, METERING LEVER	12	900500-0-0005	NUT 5	22	A160-00-3290	COVER,CYLINDER	2
123140-2-7230	GASKET,M. DIAPHRAGM	12	900502-0-0006	NUT 6 (3N)	22	A172-00-3142	COVER,FAN	8
123142-0-3930	COVER, M. DIAPHRAGM	12	900514-0-0006	NUT 6	20	A175-00-0040	STAND	14
123173-0-7930	CLIP	12	900515-0-0008	NUT, FLANGE 8	6	A202-00-0300	BELLOWS, INTAKE	10
123181-0-9560	PUMP, PRIMER	12	900518-0-0006	NUT, FLANGE	22	A206-00-0040	HOLDER, BELLOWS	10
131016-5-5830	GASKET, FUEL CAP	14	900565-0-0005	NUT	18	A209-00-1000	PLATE, INSULATOR	10
132010-0-6530	PIPE 3*6* 85	14	900602-0-0005	WASHER 5	14	A209-00-1010	PLATE, INSULATOR	10
132012-5-6030	PIPE	14	900603-0-0005	WASHER 5	20	A226-00-2030	ELEMENT, AIR FILTER	10
132115-5-5930	GROMMET, FUEL	14	900701-0-0012	CIRCLIP 12	8	A226-00-2040	ELEMENT, AIR FILTER	10
145862-4-0630	SCREEN, MUFFLER	16	900702-0-0028	CIRCLIP 28	8	A227-00-0050	PLATE, ELEMENT	10
156110-0-4920	BUSHING	6	900702-0-0042	CIRCLIP 42	8	A244-00-0320	PLATE, PREVENT	10
175046-5-6030	SHAFT, CLUTCH	8	900720-0-0022	O-RING 22	6	A313-00-2060	GUIDE, EXHAUST	16
175048-0-5530	WASHER (I)	8	900800-3-6001	BEARING, BALL 6001	4	A320-00-1200	COVER,MUFFLER	16
175049-5-6030	WASHER	8	900807-0-6001	BEARING, BALL 6001	8	A350-00-2350	TANK, FUEL	14
177220-4-0630	SPRING, REWIND	18	900810-3-6000	BEARING, BALL	4	A356-00-0031	VALVE,CHECK	14
177228-2-7030	GRIP, STARTER	18	91085-06-040	BOLT	20	A365-00-0060	CONNECTOR,CAP	14

# NUMERICAL PARTS INDEX

Part No	Part description	Page	Part No	Part description	Page	Part No	Part description	Page
A369-00-0470	STRAINER, FUEL	14	J473-00-0120	PIECE,COVER	6	P022-00-6850	PAWL, STARTER	18
A409-00-1320	ROTOR, MAGNETO	6	P003-00-1630	LEVER, METERING	12	P022-00-8270	SPRING,DAMPER	18
A411-00-1790	COIL, IGNITION	6	P003-00-1670	DIAPHRAGM, METERING	12	P022-02-2110	ROPE, STARTER	18
A413-00-0090	BOOT	8	P003-00-1710	WASHER	12	P022-03-3310	PLATE, CAM	18
A425-00-0060	SPARKPLUG	6	P003-00-4510	COVER, FUEL PUMP	12	P022-03-3320	DRUM, STARTER	18
A426-00-0010	TERMINAL, SPARKPLUG	6	P003-00-4530	GASKET, FUEL PUMP	12	P022-03-7670	STOPPER, ROPE	18
A427-00-0090	PLUG CAP	6	P003-00-4540	DIAPHRAGM, FUEL PUMP	12	P022-04-3670	STATER CASE	18
A429-00-0110	PLUG CAP COVER	6	P003-00-4560	SCREW	12	P022-04-5770	GUIDE, ROPE	18
A440-00-2800	SWITCH, ON OFF	22	P003-00-4570	SCREW	12	P100-00-2270	ARM,CLUTCH SET	8
A556-00-1760	DRUM,CLUTCH	8	P003-00-5300	BODY ASSEMBLY, PUMP	12	P100-00-3600	LID,CLEANER ASY	10
A575-00-0640	FIXTURE, MAIN PIPE	8	P003-00-5850	SWIVEL	12	P100-00-4020	MUFFLER ASY	16
C062-00-0700	HARNESS, SHOULDER	24	P003-00-5860	SCREW	12	P100-00-5150	LATCH ASY	20
C152-00-1030	CONNECTOR	6	P003-00-5870	SPRING	12	P100-00-5340	FAN COVER ASY	8
C400-00-1020	HANDLE,FRONT	20	P003-00-5880	NEEDLE	12	P100-00-5860	MAIN PIPE ASY	20
C401-00-0280	PIECE,HANDLE	20	P003-00-5890	CLIP	12	P100-00-5890	THROTTLE ASY	22
C405-00-0420	BARRIER	24	P003-00-5900	PLATE	12	V100-00-0840	GASKET,CYL	2
C450-00-0780	TRIGGER, THROTTLE	22	P021-03-5680	FUEL CAP ASY	14	V102-00-0300	GASKET, CRANKCASE	4
C460-00-0370	LOCKOUT, THROTTLE	22	P021-04-8780	HANDLE ASY	20	V103-00-1890	GASKET,INTAKE	10
C461-00-0000	LATCH,THROTTLE	22	P021-05-0840	PISTON KIT	2	V103-00-1900	GASKET,INTAKE	10
C461-00-0110	LATCH,THROTTLE	22	P021-05-0850	CRANKCASE KIT	4	V104-00-2300	GASKET,EXHAUST	16
C506-00-0550	SHAFT, FLEXIBLE	20	P021-05-0880	CLEANER CASE ASY	10	V104-00-2310	GASKET,EXHAUST	16
C510-00-0330	COUPLING, MAIN PIPE	20	P021-05-0990	HANDLE FIXTURE ASY	22	V151-00-0170	PLATE,CUP	6
C610-00-0050	FIXTURE, CUSHION	20	P021-05-1240	HOOK ASY	20	V186-00-0500	JOINT,PIPE	14
C646-00-0060	RING, HARNESS	20	P022-00-2100	E-RING	18	V253-00-1020	SCREW,5	10

## NUMERICAL PARTS INDEX

Part No	Part description	Page	Part No	Part description	Page
V263-00-0130	NUT	20	V805-00-0140	BOLT, TORX 5	20
V299-00-0640	KNOB,FASTENER	10	V805-00-0150	BOLT, TORX 5	8
V299-00-0660	KNOB,FASTENER	20	V805-00-0150	BOLT, TORX 5	10
V304-00-0040	WASHER,CIRCULAR 6	20	V805-00-0160	BOLT, TORX 5	8
V312-00-0010	WASHER,CIRCULAR 18	20	V805-00-0160	BOLT, TORX 5	14
V323-00-0070	WASHER,CIRCULAR 5	6	V805-00-0170	BOLT, TORX 5	8
V420-00-0960	CUSHION	22	V805-00-0170	BOLT, TORX 5	14
V420-00-3700	CUSHION	20	V805-00-0170	BOLT, TORX 5	22
V430-00-4940	CABLE,BOWDEN	22	V805-00-0210	BOLT, TORX 5	2
V451-00-1390	SPRING,TENSION	8	V805-00-0210	BOLT, TORX 5	6
V452-00-0120	SPRING,TORSION	22	V805-00-0220	BOLT, TORX 5	4
V471-00-1230	PIPE	14	V805-00-0250	BOLT, TORX 5	16
V475-00-7540	TUBE	6	V805-00-0340	BOLT, TORX 5	10
V475-00-8930	TUBE	22	V806-00-0020	BOLT, TORX 6	20
V485-00-2880	LEAD	6	V835-00-0010	BOLT, TORX 5	2
V490-00-1230	CLIP	14	V835-00-0010	BOLT, TORX 5	16
V490-00-1240	CLIP	14	V855-00-0000	BOLT, TORX 5	10
V503-00-0040	SEAL,OIL 10	4	X505-00-6800	LABEL,CAUTION	20
V554-00-0020	BEARING,NEEDLE 9	2	X506-00-0170	LABEL,CHOKE	10
V804-00-0030	BOLT, TORX 4	16	X562-00-1090	LABEL,SHINDAIWA	18
V805-00-0060	BOLT, TORX 5	22	X562-00-1100	LABEL,SHINDAIWA	2
V805-00-0070	BOLT, TORX 5	20	X605-00-0170	TOOL,L WRENCH	24
V805-00-0130	BOLT, TORX 5	20	X690-00-0080	GOGGLE	24
V805-00-0140	BOLT, TORX 5	18			