

HC-1501

Published:11/16/2017

TABLE OF CONTENTS

GEAR CASE, CUTTER	1
CYLINDER, CRANKCASE, PISTON	3
MAGNETO, CLUTCH.....	5
AIR CLEANER, CARBURETOR.....	7
FUEL TANK.....	9
MUFFLER.....	11
RECOIL STARTER.....	13
HANDLE.....	15
ACCESSORIES	17
CARBURETOR.....	19

GEAR CASE, CUTTER

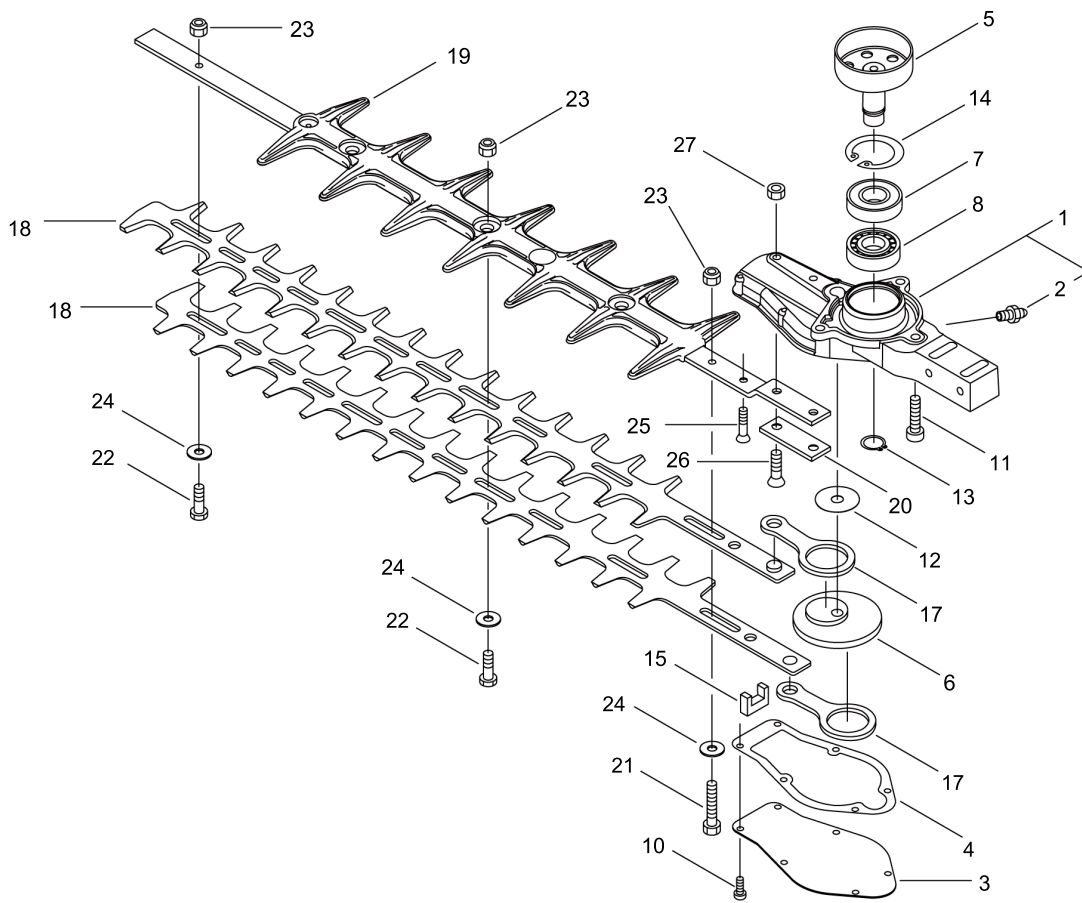

GEAR CASE, CUTTER

KEY NO	LV(+)	Part No	Description	Qty	Standard	Comment
1		P021-045620	CASE ASY, GEAR	1		
2	+	880110-10860	NIPPLE, GREASE	1		
3		610411-05361	LID, GEARCASE	1		
4		610414-05360	GASKET, GEAR HOUSING	1		
5		A556-001620	DRUM, CLUTCH	1	50 T:1.4	
6		610312-04560	GEAR	1		
7		900812-06202	BEARING, BALL 6202	1	6202DDU(LLU)	
8		900810-36202	BEARING, BALL 6202	1	6202/C3	
10		V804-000040	BOLT, TORX 4	6	TB-4*10 10.9	
11		V806-000130	BOLT, TORX 6	3		
12		610350-04560	WASHER	1		
13		900701-00014	CIRCLIP 14	1	CS-14	
14		900702-00035	CIRCLIP 35	1	CR-35	
15		610425-04560	SEAL	1		
17		C532-000121	ROD, CONNECTING	2		
18		X412-000630	CUTTER	2		
19		P021-045630	CUTTER SUPPORT ASY	1		
20		610440-04560	HOLDER, FRAME	1		
21		699115-05360	BOLT	1		
22		V204-000570	BOLT	4		
23		433022-06460	NUT	5		
24		V304-000240	WASHER	5		
25		900212-05030	SCREW (5*30*P0.8)	1	+SF5*30	
26		900212-06025	SCREW 6*25	2	+SF6*25	
27		900500-00006	NUT 6	2	6	

CYLINDER, CRANKCASE, PISTON

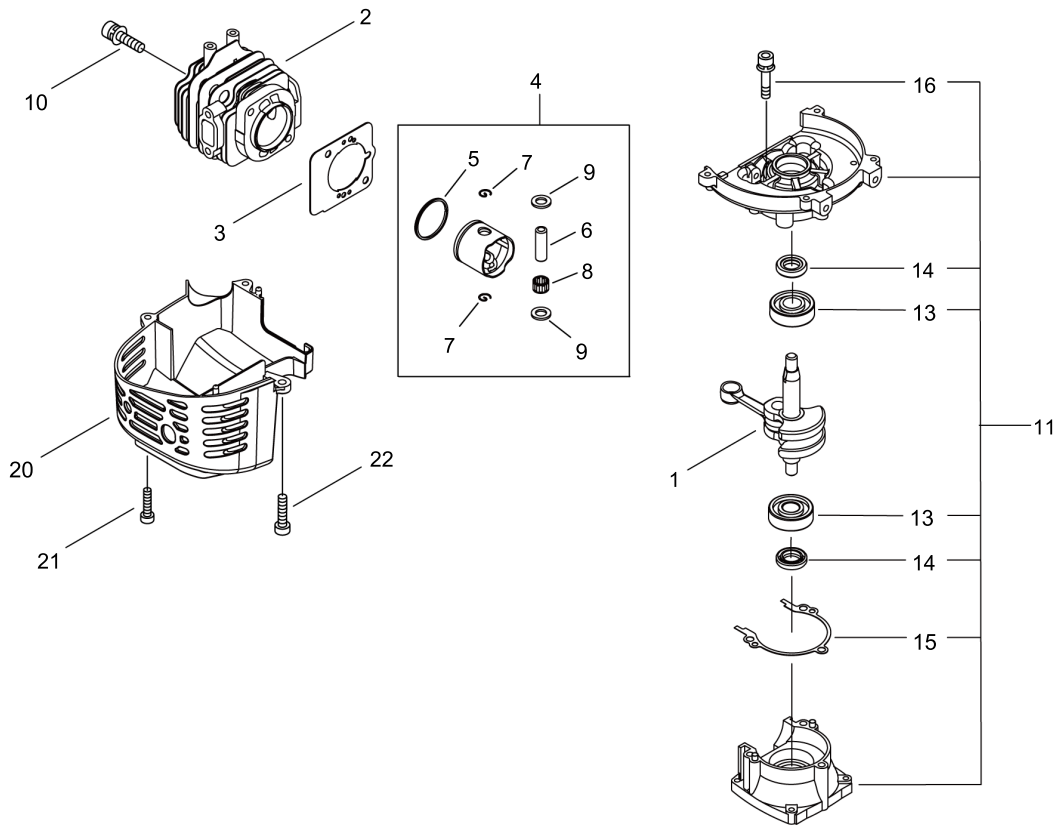

CYLINDER, CRANKCASE, PISTON

KEY NO	LV(+)	Part No	Description	Qty	Standard	Comment
1		A011-000313	CRANKSHAFT,ASM	1		
2		A130-000550	CYLINDER	1		
3		V100-000160	GASKET,CYL	1		
4		P021-007772	PISTON KIT	1		
5	+	A101-000090	RING,PISTON	1		
6	+	100013-11520	PIN, PISTON	1		
7	+	100015-04630	CIRCLIP, PISTON PIN	2		
8	+	100113-05930	BEARING, NEEDLE	1	8*12*8	
9	+	100014-08960	SPACER, PISTON PIN	2		
10		900162-05022	BOLT, H.S. 5*22	2	5*22 W,SW	
11		100204-11521	CRANKCASE KIT	1		
13	+	94035-36201	BEARING BALL	2	6201X3JR2C3	
14	+	100212-42031	OILSEAL	2	ISCD 12*22*4.5	
15	+	100242-42030	GASKET, CRANKCASE	1		
16	+	900162-05028	BOLT, H.S. 5*28	3	5*28 W,SW	
20		A160-002590	COVER,CYLINDER	1		
21		V804-000010	BOLT, TORX 4	2	TT-4*16 DG 10.9	
22		V805-000150	BOLT, TORX 5	1	TB-5*16 10.9	

MAGNETO, CLUTCH

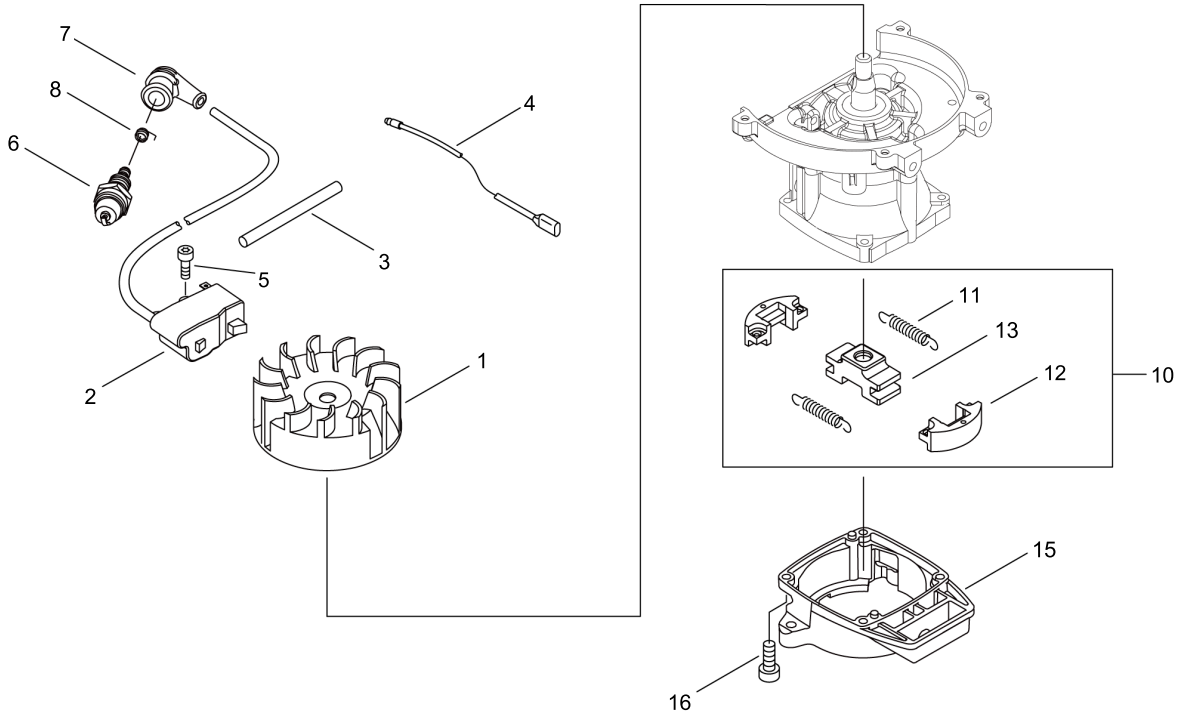

MAGNETO, CLUTCH

KEY NO	LV(+)	Part No	Description	Qty	Standard	Comment
1		A409-000150	ROTOR,MAGNETO	1		
2		A411-000210	COIL,IGNITION	1		
3		V475-007510	TUBE	1		
4		V485-000870	LEAD	1	L=190,#187, CA104	
5		V804-000070	BOLT, TORX 4	2	TB-4*20 12.9	
6		A425-000000	SPARKPLUG	1	BPMR8Y	
7		A427-000013	CAP,SPARK PLUG	1		
8		A426-000010	TERMINAL,SPARKPLUG	1		
10		A056-000740	CLUTCH ASY	1		
11	+	A566-000000	SPRING, CLUTCH	2		
12	+	175017-44331	SHOE, CLUTCH	2		
13	+	A552-000380	HUB, CLUTCH	1		
15		A570-000310	CASE,CLUTCH	1		
16		V804-000060	BOLT, TORX 4	4	TB-4*16 10.9	

AIR CLEANER, CARBURETOR

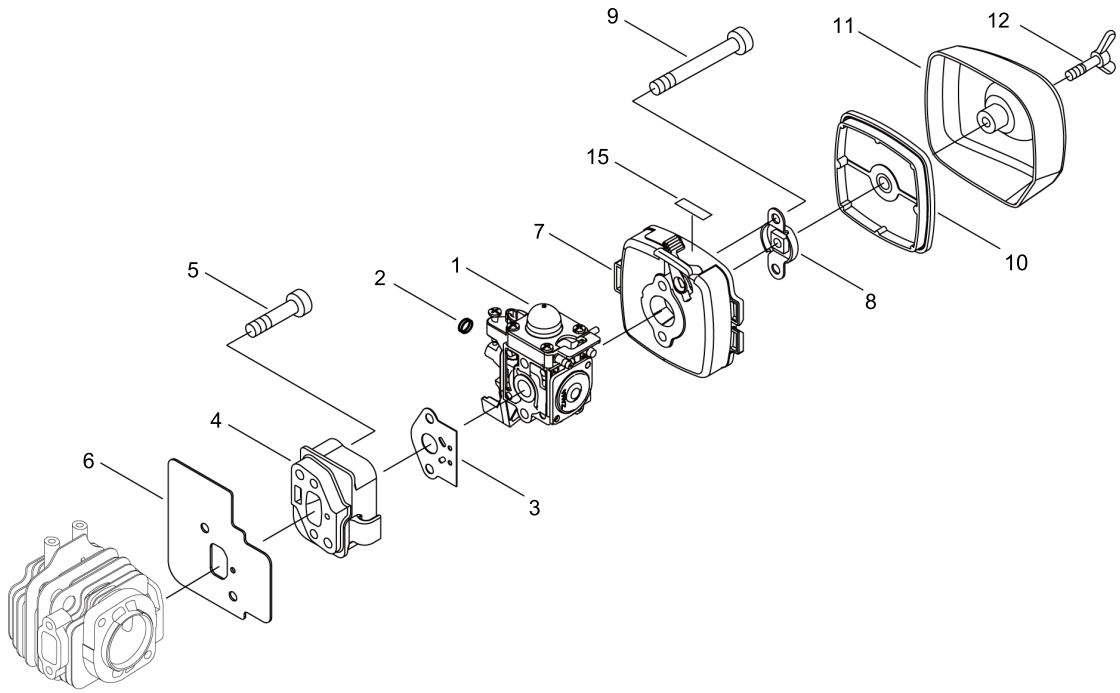

AIR CLEANER, CARBURETOR

KEY NO	LV(+)	Part No	Description	Qty	Standard	Comment
1		A021-001673	CARBURETOR, DIAPHRAGM	1		
2		V490-001100	CLIP	1		
3		V103-001580	GASKET,INTAKE	1		
4		A200-000300	INSULATOR, INTAKE	1		
5		V805-000170	BOLT, TORX 5	2	TB-5*25 10.9	
6		V103-001590	GASKET,INTAKE	1		
7		P021-004480	CASE, AIR CLEANER	1		
8		129011-52730	PLATE, PREVENT	1		
9		V805-000100	BOLT, TORX 5	2	TB-5*65 10.9	
10		A226-001410	ELEMENT,AIR FILTER	1		
11		130313-05863	LID, AIR CLEANER	1		
12		210417-52730	BOLT, WING	1	5*20	
15		890332-52730	LABEL, CHOKE	1		

FUEL TANK

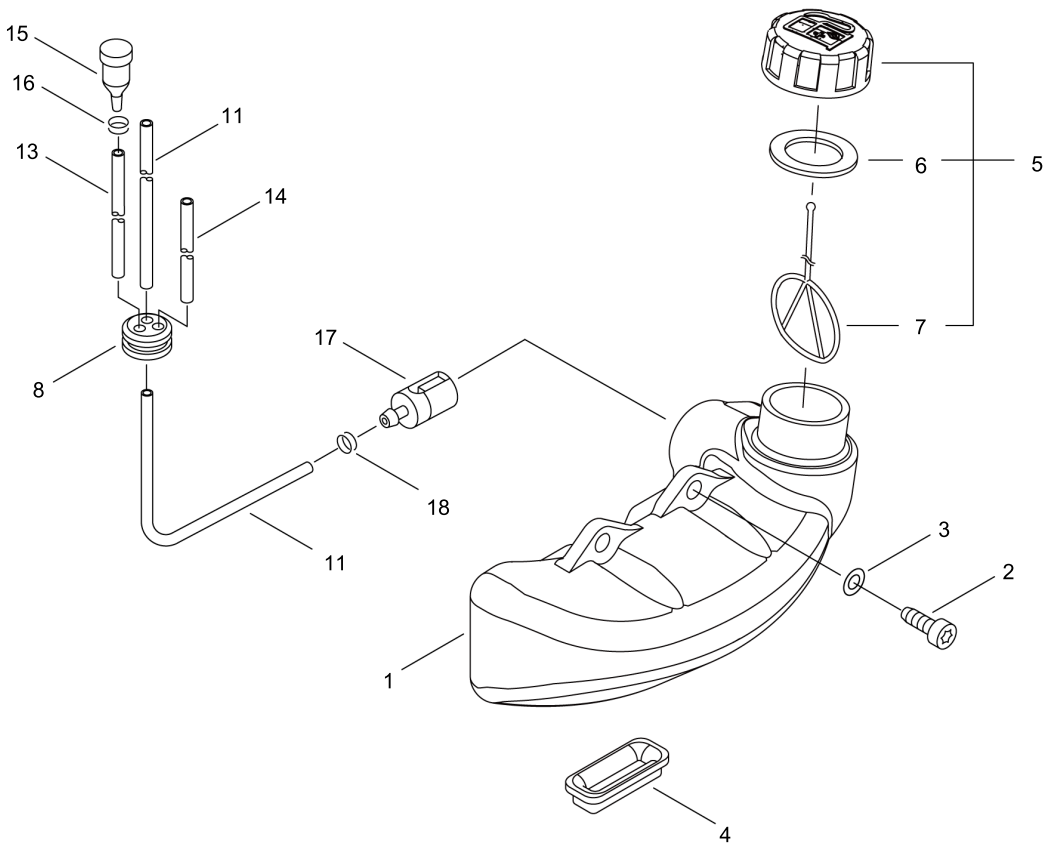

FUEL TANK

KEY NO	LV(+)	Part No	Description	Qty	Standard	Comment
1		A350-000041	TANK,FUEL	1		
2		V805-000000	BOLT, TORX 5	2	TT-5*16 DG 10.9	
3		900603-00005	WASHER 5	2	5.5*12*0.8	
4		131920-61830	CUSHION, FUEL TANK	1		
5		P021-012210	CAP,FUEL ASY	1		
6	+	131016-55830	GASKET, FUEL CAP	1		
7	+	A365-000060	CONNECTOR,CAP	1	L=123	
8		132115-46730	GROMMET, FUEL	1		
11		V470-000580	PIPE	1	3*5*195	
13		V471-001200	PIPE	1	3*5*70 NBR	
14		132010-40830	PIPE 3* 6* 75	1	3*6*75 YL	
15		A356-000031	VALVE,CHECK	1		
16		V490-001240	CLIP	1	6MM	
17		131205-07321	STRAINER, FUEL	1		
18		V490-001240	CLIP	1	6MM	

MUFFLER

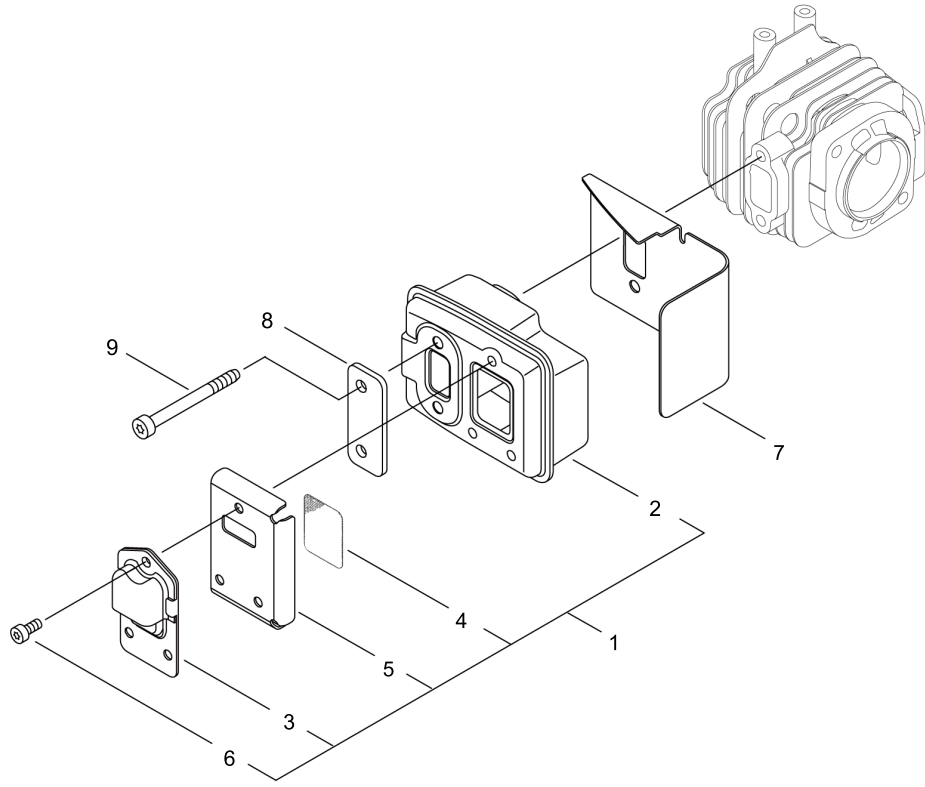

MUFFLER

KEY NO	LV(+)	Part No	Description	Qty	Standard	Comment
1		P021-045640	MUFFLER ASY	1		
2	+	A300-000521	MUFFLER,EXHAUST	1		
3	+	A313-000700	GUIDE,EXH	1	ID#1090	
4	+	145862-40630	SCREEN, MUFFLER	1		
5	+	V104-000072	GASKET,EXHAUST	1		
6	+	V804-000030	BOLT, TORX 4	3	TB-4*8 10.9	
7		V104-001990	GASKET,EXHAUST	1		
8		V150-000371	PLATE,EYE	1		
9		V805-000190	BOLT, TORX 5	2	TB-5*55 12.9	

RECOIL STARTER

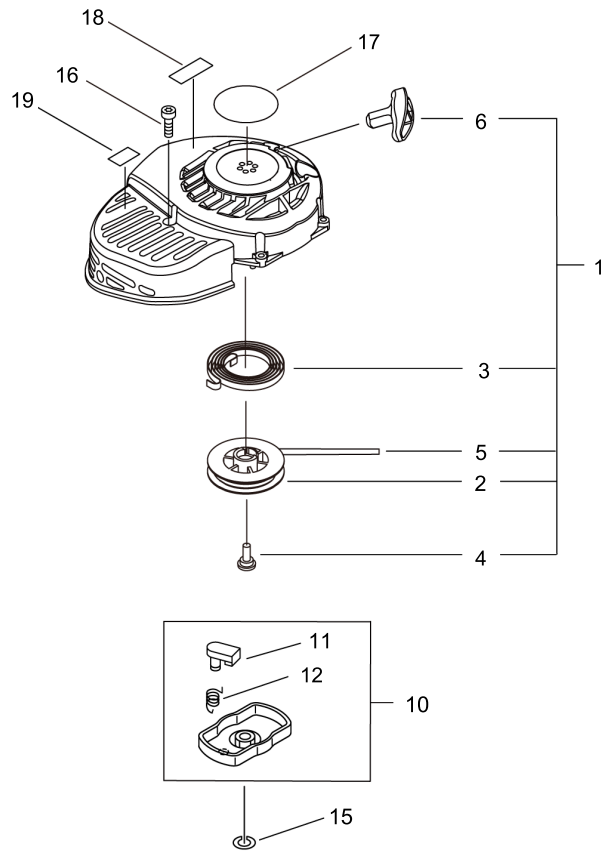

RECOIL STARTER

KEY NO	LV(+)	Part No	Description	Qty	Standard	Comment
1		A051-002590	STARTER,RECOIL ASY	1		
2	+	177215-44430	DRUM, STARTER	1		
3	+	177220-42030	SPRING, REWIND	1		
4	+	177236-44330	SCREW	1		
5	+	P022-006231	ROPE	1		
6	+	P022-023170	GRIP, STARTER	1		
10		A052-000160	PULLEY,ASM STARTER	1		
11	+	177218-44330	PAWL, STARTER	2	BLACK	
12	+	177234-12220	SPRING, PAWL	2		
15		900605-00008	WASHER, SPRING 8	1	8	
16		V804-000060	BOLT, TORX 4	4	TB-4*16 10.9	
17		X502-000890	LABEL,ECHO	1		
18		X543-004270	LABEL,MODEL	1		
19		X505-002310	LABEL,CAUTION	1	HOT CAUTION	

HANDLE

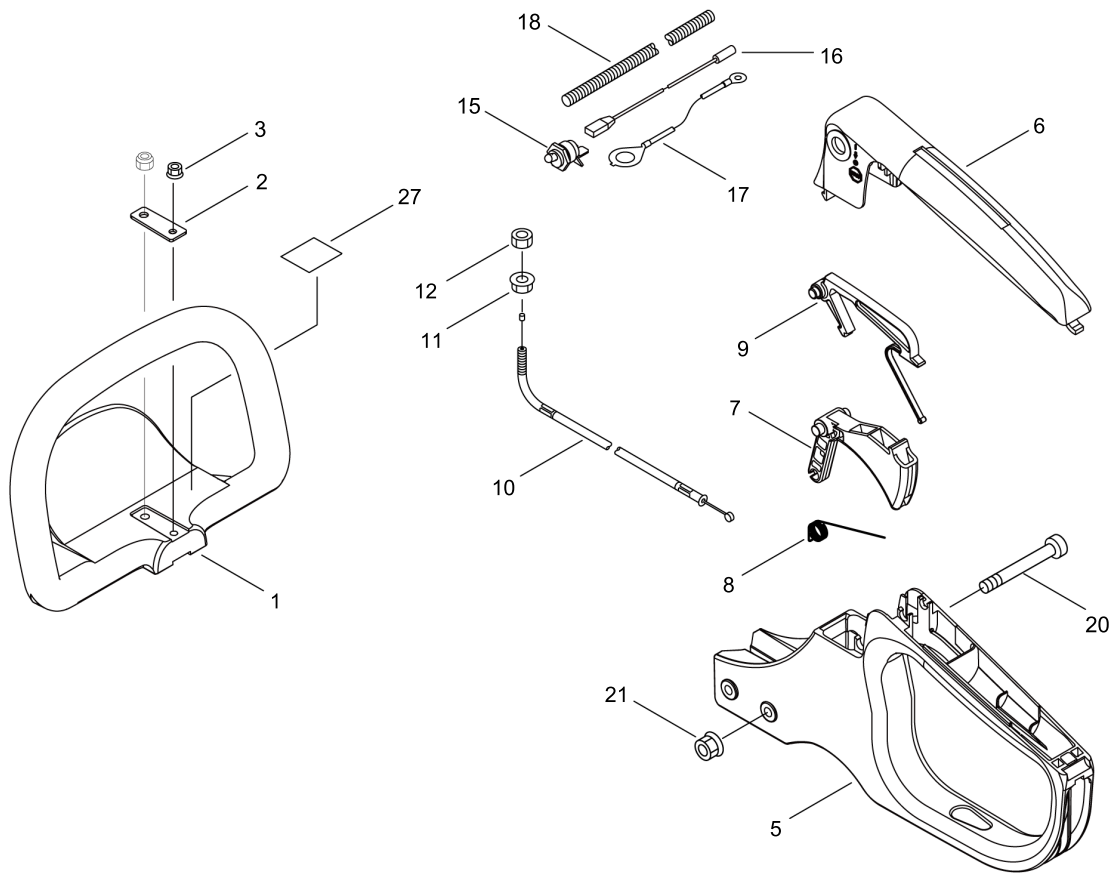

HANDLE

KEY NO	LV(+)	Part No	Description	Qty	Standard	Comment
1		C400-000532	HANDLE, FRONT	1	HC155	
2		351611-05360	WASHER	1		
3		92108-05000	NUT, FLANGE	1		
5		C410-000430	HANDLE, REAR	1		
6		C411-000030	LID,HANDLE	1		
7		C450-000750	TRIGGER,THROTTLE	1		
8		V452-000392	SPRING,TORSION	1	11.5 ID	
9		C460-000120	LOCKOUT, THROTTLE	1		
10		V430-004670	CABLE,BOWDEN	1		
11		900515-00006	NUT, FLANGE 6	1	6	
12		900502-00006	NUT 6 (3N)	1	3N6	
15		163400-03460	SWITCH, IGNITION	1		
16		V485-002540	LEAD	1		
17		V485-002550	LEAD	1		
18		V475-001280	TUBE	1	7*140 コルゲート	
20		V805-000280	BOLT, TORX 5	2	TB-5*45 10.9	
21		92108-05000	NUT, FLANGE	2		
27		X505-002030	LABEL,CAUTION	1	37*35	

ACCESSORIES

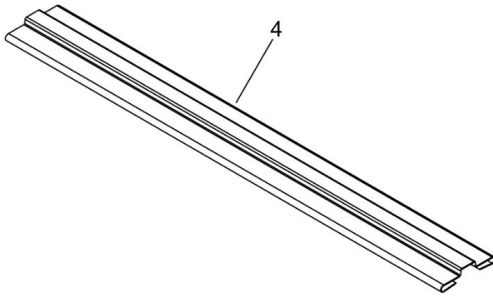
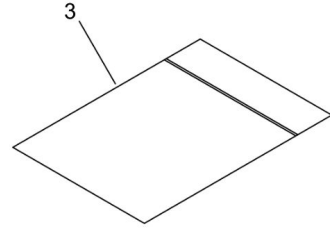
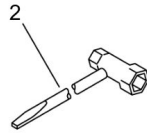
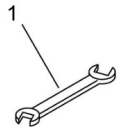

ACCESSORIES

KEY NO	LV(+)	Part No	Description	Qty	Standard	Comment
1		895112-00330	SPANNER 8*10	1		
2		895410-03930	WRENCH, W/S. DRIVER	1		
3		X698-000050	TOOL,CASE	1	140*260*0.06	
4		X495-000540	SCABBARD,BLADE	1	L585	

CARBURETOR

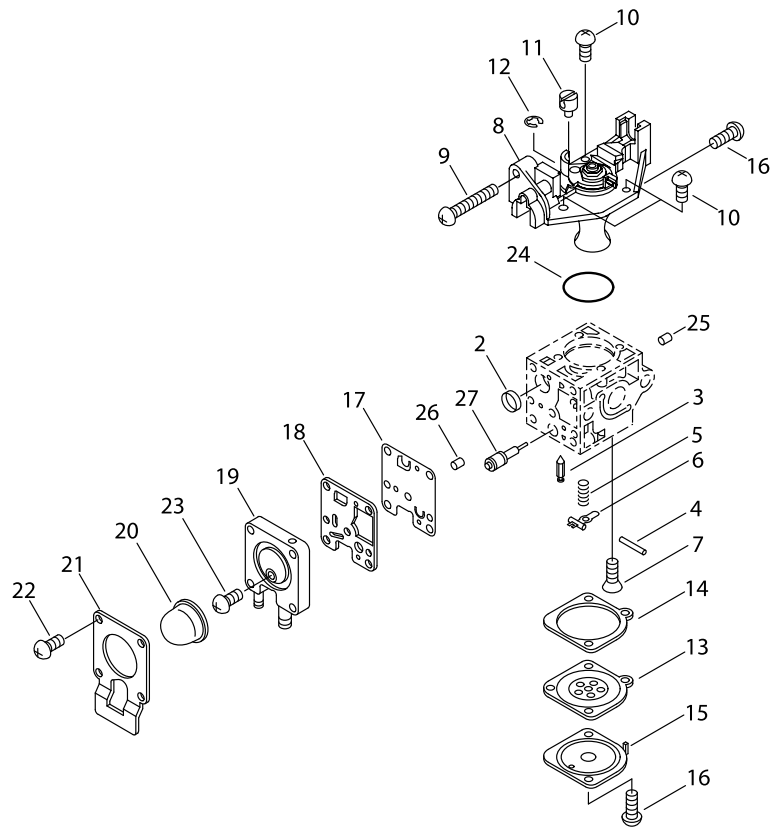

CARBURETOR

KEY NO	LV(+)	Part No	Description	Qty	Standard	Comment
		A021-001673	CARBURETOR, DIAPHRAGM	1		
2	+	P005-000010	STRAINER	1		
3	+	125337-08260	VALVE, INLET NEEDLE	1		
4	+	125338-13930	PIN, METERING ARM	1		
5	+	P005-000940	SPRING, METER. LEVER	1		
6	+	125323-08260	ARM, VALVE	1		
7	+	125339-42030	SCREW	1		
8	+	P005-002050	COVER ASY, ROTOR	1		
9	+	P005-000100	SCREW, THROTTLEADJUST	1		
10	+	125344-13931	SCREW	3		
11	+	P005-002200	POST	1		
12	+	P005-000190	E-RING	1		
13	+	P005-002230	DIAPHRAGM ,METERING	1		
14	+	P005-000200	GASKET, METERING	1		
15	+	125342-52130	COVER, DIAPHRAGM	1		
16	+	125344-52130	SCREW	3		
17	+	P005-000510	DIAPHRAGM, PUMP	1		
18	+	P005-000520	GASKET, PUMP	1		
19	+	P005-002480	BASE ASY,PRIMER	1		
20	+	P005-003110	PUMP, PRIMER	1		
21	+	P005-000250	RETAINER	1		
22	+	P005-001900	SCREW	4		
23	+	P005-000270	SCREW	1		
24	+	P005-000280	O-RING	1		
25	+	P005-001000	ROLLER, GUIDE	1		
26	+	P005-001250	RETAINER,PLUG BALL	1		
27	+	P005-001260	SCREW,MAINN MIXTURE	1		

NUMERICAL PARTS INDEX

Part No	Part description	Page	Part No	Part description	Page	Part No	Part description	Page
100013-11520	PIN, PISTON	4	900212-05030	SCREW (5*30*P0.8)	2	P005-000010	STRAINER	20
100014-08960	SPACER, PISTON PIN	4	900212-06025	SCREW 6*25	2	P005-000100	SCREW, THROTTLEADJUST	20
100015-04630	CIRCLIP, PISTON PIN	4	900500-00006	NUT 6	2	P005-000190	E-RING	20
100113-05930	BEARING, NEEDLE	4	900502-00006	NUT 6 (3N)	16	P005-000200	GASKET, METERING	20
100204-11521	CRANKCASE KIT	4	900515-00006	NUT, FLANGE 6	16	P005-000250	RETAINER	20
100212-42031	OILSEAL	4	900603-00005	WASHER 5	10	P005-000270	SCREW	20
100242-42030	GASKET, CRANKCASE	4	900605-00008	WASHER, SPRING 8	14	P005-000280	O-RING	20
125323-08260	ARM, VALVE	20	900701-00014	CIRCLIP 14	2	P005-000510	DIAPHRAGM, PUMP	20
125337-08260	VALVE, INLET NEEDLE	20	900702-00035	CIRCLIP 35	2	P005-000520	GASKET, PUMP	20
125338-13930	PIN, METERING ARM	20	900810-36202	BEARING, BALL 6202	2	P005-000940	SPRING, METER. LEVER	20
125339-42030	SCREW	20	900812-06202	BEARING, BALL 6202	2	P005-001000	ROLLER, GUIDE	20
125342-52130	COVER, DIAPHRAGM	20	92108-05000	NUT, FLANGE	16	P005-001250	RETAINER,PLUG BALL	20
125344-13931	SCREW	20	94035-36201	BEARING BALL	4	P005-001260	SCREW,MAINN MIXTURE	20
125344-52130	SCREW	20	A011-000313	CRANKSHAFT,ASM	4	P005-001900	SCREW	20
129011-52730	PLATE, PREVENT	8	A021-001673	CARBURETOR, DIAPHRAGM	8	P005-002050	COVER ASY, ROTOR	20
130313-05863	LID, AIR CLEANER	8	A021-001673	CARBURETOR, DIAPHRAGM	20	P005-002200	POST	20
131016-55830	GASKET, FUEL CAP	10	A051-002590	STARTER,RECOIL ASY	14	P005-002230	DIAPHRAGM ,METERING	20
131205-07321	STRAINER, FUEL	10	A052-000160	PULLEY,ASM STARTER	14	P005-002480	BASE ASY,PRIMER	20
131920-61830	CUSHION, FUEL TANK	10	A056-000740	CLUTCH ASY	6	P005-003110	PUMP, PRIMER	20
132010-40830	PIPE 3* 6* 75	10	A101-000090	RING,PISTON	4	P021-004480	CASE, AIR CLEANER	8
132115-46730	GROMMET, FUEL	10	A130-000550	CYLINDER	4	P021-007772	PISTON KIT	4
145862-40630	SCREEN, MUFFLER	12	A160-002590	COVER,CYLINDER	4	P021-012210	CAP,FUEL ASY	10
163400-03460	SWITCH, IGNITION	16	A200-000300	INSULATOR, INTAKE	8	P021-045620	CASE ASY, GEAR	2
175017-44331	SHOE, CLUTCH	6	A226-001410	ELEMENT,AIR FILTER	8	P021-045630	CUTTER SUPPORT ASY	2
177215-44430	DRUM, STARTER	14	A300-000521	MUFFLER,EXHAUST	12	P021-045640	MUFFLER ASY	12
177218-44330	PAWL, STARTER	14	A313-000700	GUIDE,EXH	12	P022-006231	ROPE	14
177220-42030	SPRING, REWIND	14	A350-000041	TANK,FUEL	10	P022-023170	GRIP, STARTER	14
177234-12220	SPRING, PAWL	14	A356-000031	VALVE,CHECK	10	V100-000160	GASKET,CYL	4
177236-44330	SCREW	14	A365-000060	CONNECTOR,CAP	10	V103-001580	GASKET,INTAKE	8
210417-52730	BOLT, WING	8	A409-000150	ROTOR,MAGNETO	6	V103-001590	GASKET,INTAKE	8
351611-05360	WASHER	16	A411-000210	COIL,IGNITION	6	V104-000072	GASKET,EXHAUST	12
433022-06460	NUT	2	A425-000000	SPARKPLUG	6	V104-001990	GASKET,EXHAUST	12
610312-04560	GEAR	2	A426-000010	TERMINAL,SPARKPLUG	6	V150-000371	PLATE,EYE	12
610350-04560	WASHER	2	A427-000013	CAP,SPARK PLUG	6	V204-000570	BOLT	2
610411-05361	LID, GEARCASE	2	A552-000380	HUB, CLUTCH	6	V304-000240	WASHER	2
610414-05360	GASKET, GEAR HOUSING	2	A556-001620	DRUM, CLUTCH	2	V430-004670	CABLE,BOWDEN	16
610425-04560	SEAL	2	A566-000000	SPRING, CLUTCH	6	V452-000392	SPRING,TORSION	16
610440-04560	HOLDER, FRAME	2	A570-000310	CASE,CLUTCH	6	V470-000580	PIPE	10
699115-05360	BOLT	2	C400-000532	HANDLE, FRONT	16	V471-001200	PIPE	10
880110-10860	NIPPLE, GREASE	2	C410-000430	HANDLE, REAR	16	V475-001280	TUBE	16
890332-52730	LABEL, CHOKE	8	C411-000030	LID,HANDLE	16	V475-007510	TUBE	6
895112-00330	SPANNER 8*10	18	C450-000750	TRIGGER,THROTTLE	16	V485-000870	LEAD	6
895410-03930	WRENCH, W/S. DRIVER	18	C460-000120	LOCKOUT, THROTTLE	16	V485-002540	LEAD	16
900162-05022	BOLT, H.S. 5*22	4	C532-000121	ROD, CONNECTING	2	V485-002550	LEAD	16
900162-05028	BOLT, H.S. 5*28	4						

NUMERICAL PARTS INDEX

Part No	Part description	Page
V490-001100	CLIP	8
V490-001240	CLIP	10
V804-000010	BOLT, TORX 4	4
V804-000030	BOLT, TORX 4	12
V804-000040	BOLT, TORX 4	2
V804-000060	BOLT, TORX 4	6
V804-000060	BOLT, TORX 4	14
V804-000070	BOLT, TORX 4	6
V805-000000	BOLT, TORX 5	10
V805-000100	BOLT, TORX 5	8
V805-000150	BOLT, TORX 5	4
V805-000170	BOLT, TORX 5	8
V805-000190	BOLT, TORX 5	12
V805-000280	BOLT, TORX 5	16
V806-000130	BOLT, TORX 6	2
X412-000630	CUTTER	2
X495-000540	SCABBARD, BLADE	18
X502-000890	LABEL, ECHO	14
X505-002030	LABEL, CAUTION	16
X505-002310	LABEL, CAUTION	14
X543-004270	LABEL, MODEL	14
X698-000050	TOOL, CASE	18